

# Electronic capacity indicator

## ECI

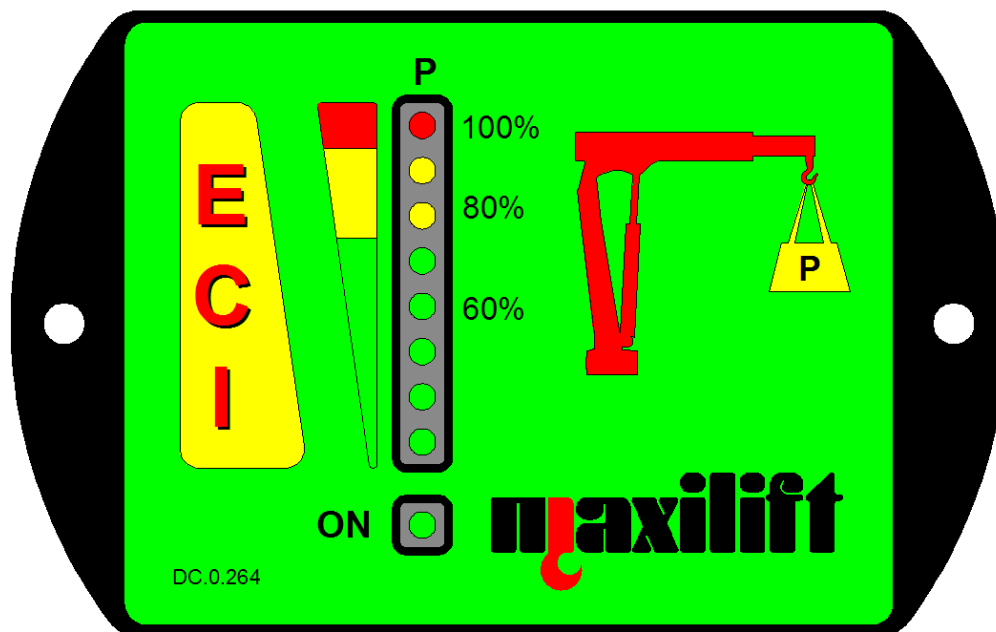

## Operation & Instruction Manual (Part 2 of 4)

Rev. 1  
Ed. 06/17

## Index

|          |  |           |
|----------|--|-----------|
| <b>1</b> | <b>Functioning</b> .....                           | Page... 2 |
| <b>2</b> | <b>Components overview</b> .....                   | “ ..... 2 |
| 2.1      | Components description.....                        | “ ..... 2 |
| 2.1.1    | Control unit box.....                              | “ ..... 3 |
| 2.1.2    | Pressure transducer.....                           | “ ..... 3 |
| <b>3</b> | <b>Overall wiring diagram</b> .....                | “ ..... 3 |
| <b>4</b> | <b>Calibration</b> .....                           | “ ..... 3 |
| <b>5</b> | <b>Diagnostic informations</b> .....               | “ ..... 4 |
| 5.1      | Technical data.....                                | “ ..... 4 |
| 5.2      | Protections of the system.....                     | “ ..... 4 |
| 5.3      | LED error message.....                             | “ ..... 4 |
| 5.4      | Testing the pressure transducer .....              | “ ..... 4 |
| 5.4.1    | Explanation of the ratiometric output signal.....  | “ ..... 4 |
| 5.4.2    | Test procedure .....                               | “ ..... 5 |
| 5.5      | Steps to follow when the red LED is blinking.....  | “ ..... 5 |
| 5.5.1    | Instruction for carrying out an in-line cable..... | “ ..... 6 |

# 1 Functioning

The "ECI" is a device displaying the lifted load level by means of a LEDs scale. The lower green LED (ON), separate from the others, indicates that the system is live. Five further green LEDs (60%) indicate percent rates from 30% to 70% of the maximum rated capacity allowed, the two yellow LEDs (80%) indicate 80% and 90%, while the red LED (100%) shows that the maximum rated capacity allowed for the crane has been reached or exceeded. **The operator shall prevent lighting up of the red LED (overload) while using the crane.**

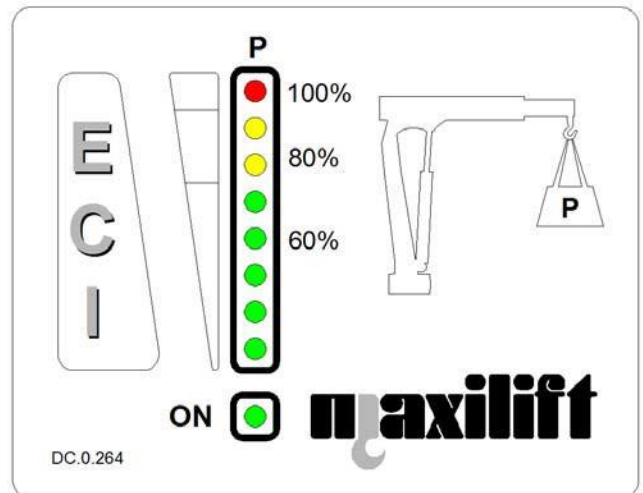

## ATTENTION

The ECI system is no safety device, rather a display system, as it does not lock the crane in case of overload.

Pict. 1

# 2 Components overview

## 2.1 Components description (Pict. 2)

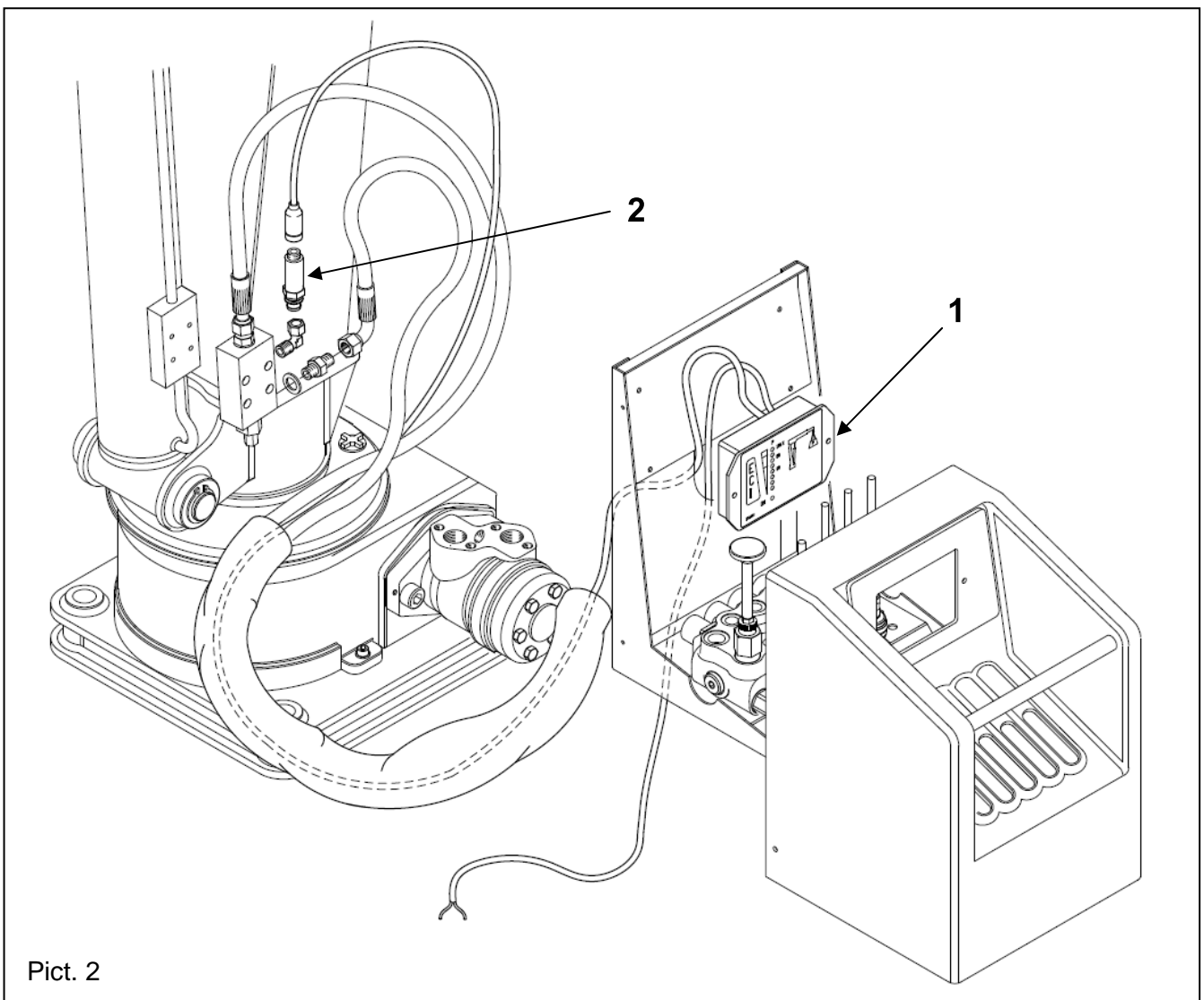

Pict. 2

### 2.1.1 Control unit box (1, Pict. 2)

It is placed on the control station, and contains the electronic card that processes the signal coming from the pressure transducer. The frontal panel allows the visualization of the signals from the electronic card.

### 2.1.2 Pressure transducer (2, Pict. 2)

It is fitted on the over centre valve of the lifting cylinder, to sense the pressure inside the bottom side of the lifting cylinder itself. Its output is a variable electric signal, proportional to the pressure.

## 3 Overall wiring diagram (Pict. 3)

The system is made by an electronic card and a pressure transducer, with the relevant supply cables. The LEDs of the card are visible on the front side panel of the enclosure. The voltage supply cable for the card and the cable for the transducer are directly soldered on the card. Therefore, their connection to the card is not accessible. The cables just come out from the card on the rear side of the enclosure.

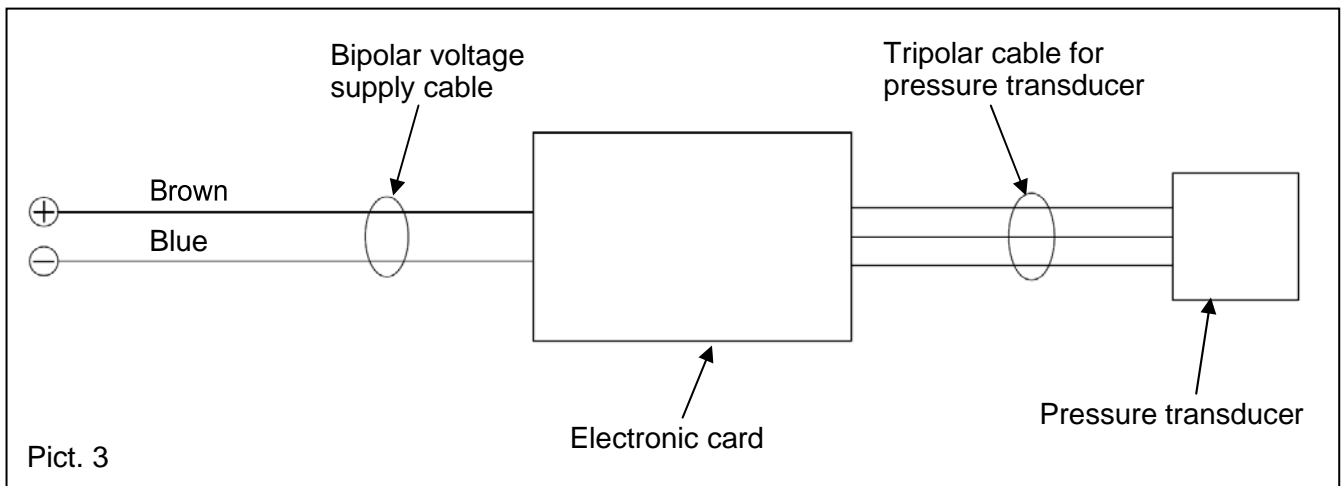

## 4 Calibration (Pict. 4)

- When the system is ON, bring the nominal load at the maximum outreach.
- Bridge terminals 5 and 6 of the connector for at least one second.
- Check that all the LEDs are lit up.
- Retract the extensions, checking that the LEDs turn OFF one by one.

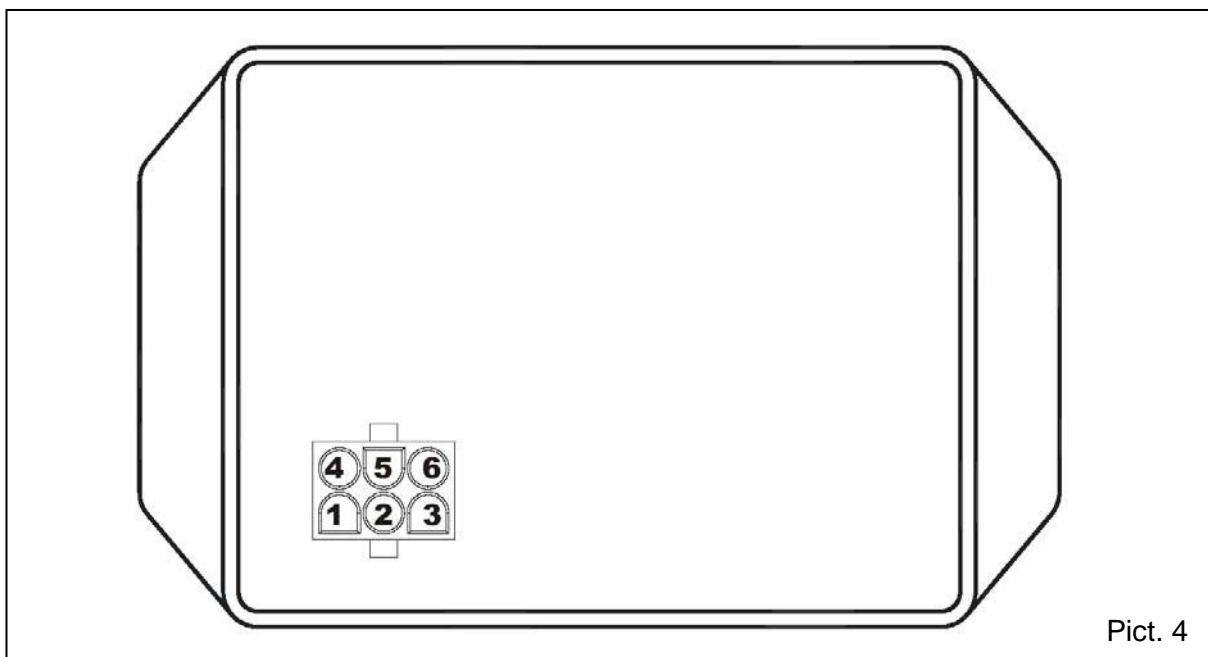

## 5 Diagnostic information

### 5.1 Technical data

Permissible supply voltage range:  $9 \div 33$  V

Permissible working temperature range:  $-40 \div 70^{\circ}\text{C}$

Current absorption of the whole system (electronic card + pressure transducer):  
60 mA (independently from the supply voltage)

The system complies with the norms:

EN 61000-6-2

EN 61000-6-3

The system complies with Category B according to EN 954-1

### 5.2 Protections of the system

The electronic card is protected against:

- polarity inversion
- disconnection or shorting of the pressure transducer wires

### 5.3 LED error message

The only possible error message is the following:

Red LED (100%) blinking

It indicates an error on the pressure transducer or its wiring that could be due to:

- Signal from pressure transducer not correct (check the part number and the signal type of the pressure transducer, first – see 5.3)
- Signal from pressure transducer missing
- Pressure transducer not supplied

### 5.4 Testing the pressure transducer (part number LM.1.015)

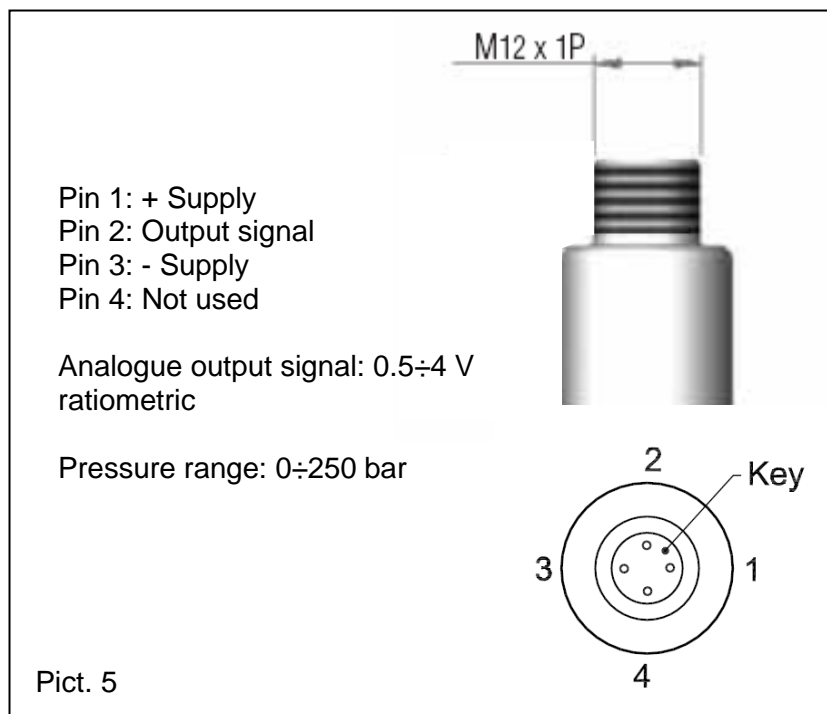

#### 5.4.1 Explanation of the ratiometric output signal

The supply voltage has to be 5V. The ratiometric output signal is to be calculated as a percentage of 5V supply voltage. The ratiometric percentage range is  $10\% \div 80\%$ . Therefore, the output signal range is  $0.5\text{V} \div 4\text{V}$ .

### 5.4.2 Test procedure

Supply the transducer with a voltage of 5 V, and measure the voltage on the output signal line. Theoretically, the current values to be read should be **0.5 V at 0 bar** and **4 V at 250 bar**. The tolerance is  $\pm 0.5\%$  of the analogue output signal range, that is 3.5V (4-0.5), therefore 0.0175 V. This means that, at 0 bar, can be read a voltage from 0.4825 V to 0.5175 V, while at 250 bar, can be read a voltage from 3.9825 V to 4.0175 V. Should be needed to know which voltage value should be read at 100 bar, it's necessary to write the proportion  $3.5/250=x/100$ , which result is  $x= 3.5*100/250$ . The voltage value is **V = 0.5 + x**.

Example table:

| Pressure<br>bar | Voltage DC   |           |           |
|-----------------|--------------|-----------|-----------|
|                 | Nominal<br>V | min.<br>V | max.<br>V |
| 0               | 0.5          | 0.4825    | 0.5175    |
| 50              | 1.2          | 1.1825    | 1.2175    |
| 100             | 1.9          | 1.8825    | 1.9175    |
| 150             | 2.6          | 2.5825    | 2.6175    |
| 200             | 3.3          | 3.2825    | 3.3175    |
| 250             | 4            | 3.9825    | 4.0175    |

### 5.5 Steps to follow when the red LED is blinking

Check first that the cable-connector is well tightened to the pressure transducer. If yes, check, at first sight, if the cable from the pressure transducer up to the protection sheath, towards the control unit box, is not damaged externally. Check also that the pressure transducer is not damaged externally. If all looks in good condition, proceed as follows.

- Disconnect the cable from the pressure transducer. With the ECI connected to the battery, measure the voltage on pin 1 inside the connector of the cable (Pict. 6). The voltage should be around 5 V.
- Check continuity between the minus on the battery and the pin 3.
- If one of these two measures is not OK, there are the following possible situations: faulty connector; cable interrupted inside somewhere (hopefully, it's possible to cut it and make a junction); faulty electronic card.
- If instead the two measures are OK, now only the line of the pin 2 remains to check. For this, there's no other way out than making an in-line cable (see paragraph 5.4.1), and connect it between cable and pressure transducer. Check that, without pressure, the voltage on this pin is around 0.5 V. If it is 0, the problem is on the transducer.
- Test the pressure transducer alone with a separate cable, like explained in paragraph 5.3. If it is OK, the problem can be in the cable (or in the connector), or the electronic card (line of pin 2).

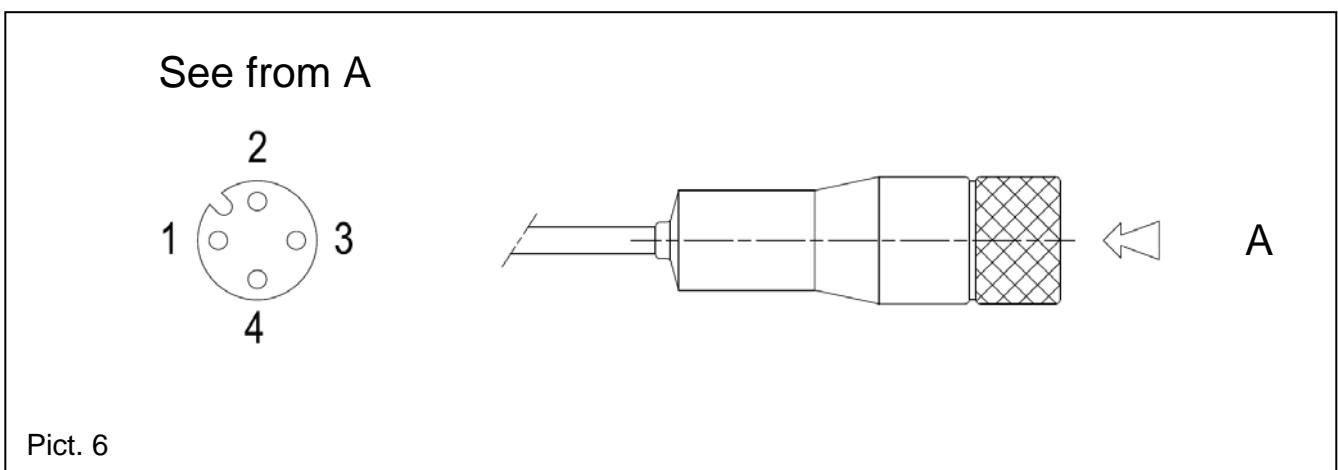

### 5.5.1 Instruction for carrying out an in-line cable (Pict. 7)

- Use wire markers or numbered wires
- Connect the numbered/marked wires to the relevant pins on the connectors

