

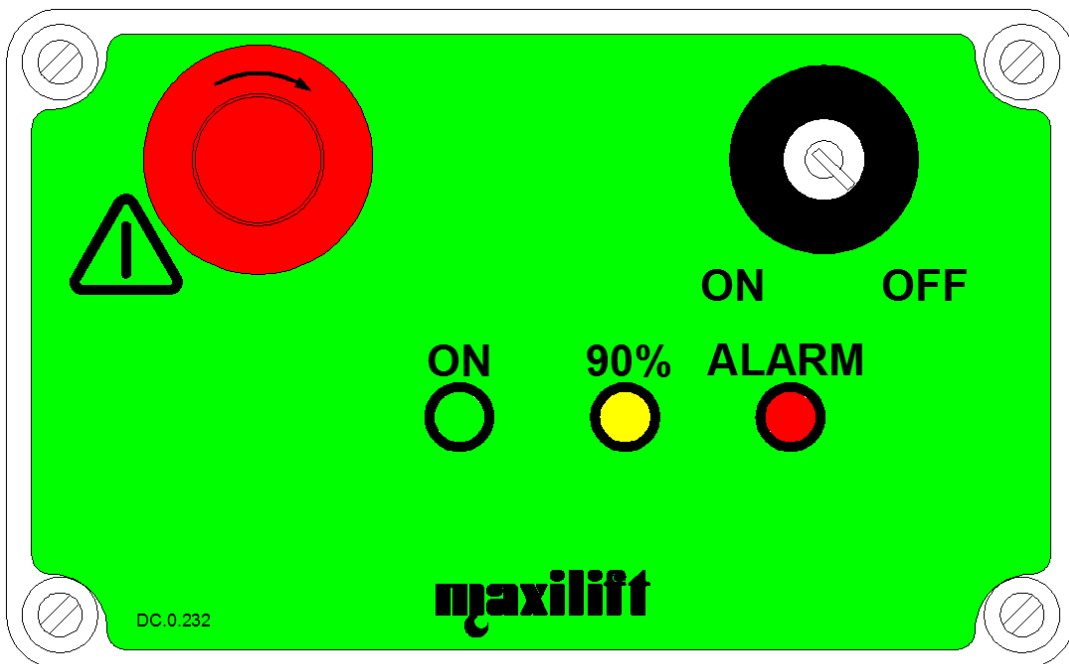

Electronic load limiter

LME04



Installation, Operating & Maintenance Manual (Part 4 of 4)

Rev. 1 – Ed. 06/17

Index

1	Functioning	Page... 3
1.1	Lifting moment locking by the basic system	“ 3
1.2	Lifting moment locking with additional safety systems	“ 4
1.2.1	Lifting moment locking with winch stop-end system.....	“ 4
1.2.2	Lifting moment locking with SCU.....	“ 4
2	Components overview	“ 4
2.1	Components description.....	“ 4
2.1.1	Control unit box.....	“ 5
2.1.2	Pressure transducer.....	“ 5
2.1.3	Reset micro-switch (extension in).....	“ 5
2.1.4	Centralized micro-switch.....	“ 5
2.1.5	Dump solenoid valve.....	“ 7
2.1.6	Emergency manual override.....	“ 7
2.1.7	Controls cover.....	“ 7
2.2	Components of the basic load limiter.....	“ 8
2.3	Cards layout and parts.....	“ 9
3	Electrical connection of the system	“ 11
4	Check of the load limiter system functionality	“ 11
4.1	Protections of the system.....	“ 11
4.2	Calibration of the load limiter system.....	“ 12
4.2.1	Preparation for the setting.....	“ 12
4.2.2	Calibration procedure.....	“ 12
4.2.3	Checks	“ 12
4.2.4	Sealing the system.....	“ 12
4.3	Safety checks.....	“ 13
4.4	Check of the emergency button functionality.....	“ 13
4.5	Setting of the over centre valve on the lifting cylinder	“ 13
4.6	Purpose and meaning of the front cover lamps	“ 13
4.7	Error code messages from the LEDs on the electronic card	“ 14
5	Safety tips, checks and maintenance	“ 15
5.1	Safety tips	“ 15
5.2	Checks and maintenance	“ 15
5.2.1	Checks after the installation of the load limiter on the crane	“ 15
5.2.2	Checks before every working session with the crane.....	“ 15
5.2.3	Special maintenance.....	“ 15
6	Wiring diagrams	“ 15
6.1	Connection diagram of the basic load limiter.....	“ 16
6.2	Winch stop-end system wiring diagram	“ 17
6.2.1	Behaviour of the system	“ 17
6.3	Slew limiter wiring diagram	“ 18
6.3.1	Behaviour of the system	“ 19
6.4	SCU wiring diagram for crane with main stabilizer, without supplementary stabilizer.....	“ 20
6.5	SCU wiring diagram for crane with main stabilizer and supplementary stabilizer	“ 21
6.6	Winch pull limiter wiring diagram	“ 22
6.6.1	Behaviour of the system	“ 23
7	Troubleshooting	“ 24
7.1	Table of possible faults	“ 24
7.2	Testing the pressure transducer with error code E4.....	“ 25
7.2.1	Internal error code: Green LED D19 = 1 flash	“ 25
7.2.2	Internal error code: Green LED D19 = 5 flashes	“ 25
7.3	Testing the pressure transducer disconnected from the load limiter	“ 26
8	Stability control unit SCU	“ 27
8.1	Operating logic.....	“ 27
8.2	Modification of the setting of the load limiter low threshold	“ 28
8.2.1	Preparation for the setting.....	“ 28

8.2.2	Calibration procedure.....	“	28
8.2.3	Checks	“	28
8.2.4	Sealing the system.....	“	28
8.3	SCU system components	“	29
8.3.1	SCU control unit.....	“	30
8.3.2	Stability sensors.....	“	30
8.3.2.1	Extension sensors	“	30
8.3.2.2	Ground contact sensors.....	“	30
8.3.3	Boom stowage micro-switch MB.....	“	30
8.3.4	Boom lowering micro-switch MD.....	“	31
8.3.5	Proximity on the stabilizer function lever PL	“	31
8.3.6	Harness	“	31
8.4	Diagnostic and anomalous operating conditions	“	32
8.4.1	MB lever stuck in the position it has when the boom is folded	“	32
8.5	Important information for replacing components	“	32
8.5.1	Replacing the load limiter main board	“	32
8.5.2	Replacing the SCU control unit.....	“	32

Foreword

This manual is addressed to the installers of **PH** cranes, for the models equipped with the **LME 04** load limiter. It is advisable, before connecting, starting crane operation or acting on the system, to carefully read this manual, in order to fully understand the safety functions.

It's necessary to pay special attention where the following symbol appears:



It is used to highlight important notes inside the text, or to warn from the possibility of risks of damaging the system or danger to persons.

1 Functioning

The load limiter **LME04**, besides locking the crane when overload occurs, also carries out further safety functions: emergency stop; checking for control levers stuck in activation position, when turning the system ON; managing the following additional safety systems it can be integrated with, in a modular way:

- Winch stop-end system (paragraphs 6.2 – 6.2.1)
- Slew limiter (paragraphs 6.3 – 6.3.1)
- Stability control system SCU (chapter 8)
- Winch pull limiter (paragraph 6.6)

1.1 Lifting moment locking by the basic system (without additional safety systems)

The device intervenes and locks the crane functions, when the pressure in the bottom side of the lifting cylinder reaches the pre-set value, corresponding with the nominal lifting moment of the crane, increased as described in paragraph 4.2.1. The nominal lifting moment of the crane (Pict. 1) is $M = P \times L$, being **P** one of the loads indicated on the load chart, and **L** is the relevant outreach. In overload condition (lifting moment locking), the red LED (**1**) on the panel lights up, and all the functions are locked except for the extension in.

When retracting the extensions, the red LED lights OFF, and the yellow LED lights up (**2**) (forewarning). In order to be able to work without getting the crane locked again, it's necessary to retract further the extensions, until the yellow LED lights OFF. In fact, both when lifting and when lowering the load, originates dynamic actions on the load, that make the pressure, inside the lifting cylinder, increase, so that the system gets locked again.

In forewarning condition (yellow LED lit up), only slow operation avoids the crane to get locked.

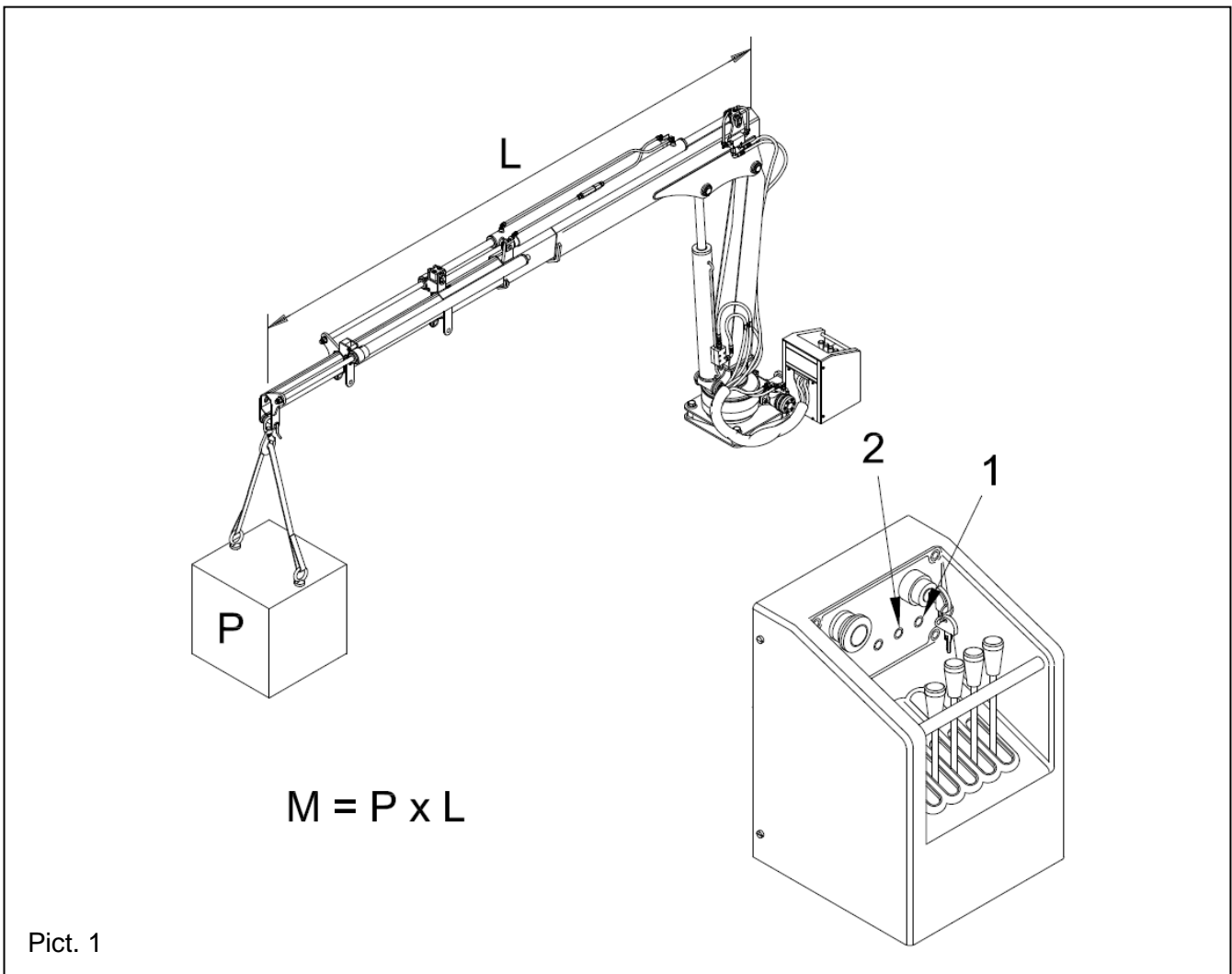

Pict. 1

1.2 Lifting moment locking with additional safety systems

The safety systems of the LME04 adds further safety functionality, related to other safety devices, as described in the relevant sections of the manual. But, as far as the condition of lifting moment locking is concerned, it's useful to highlight variations relating to the alarm condition. In respect of the basic system, in the following two cases:

1.2.1 Lifting moment locking with winch stop-end system

It is possible to exit from the lifting moment locking alarm by activating the winch down function or by operating the extension in function.

1.2.2 Lifting moment locking with SCU

Only when the system is integrated with the SCU, the load limiter works with two alarm thresholds. The high threshold is set as described in paragraph 1.1, to allow the crane to work at the full rated capacity only when the stabilizers are completely set. Otherwise, the system works in the low threshold.

The purpose of the low threshold is not to protect the crane structure from overload, but to prevent the overturning of the vehicle, if not stabilized. In condition of low threshold alarm, the extension in is still the reset function, but it's possible to activate the boom lowering function, for half second every 10 seconds.

2 Components overview

2.1 Components description (Pict. 2)

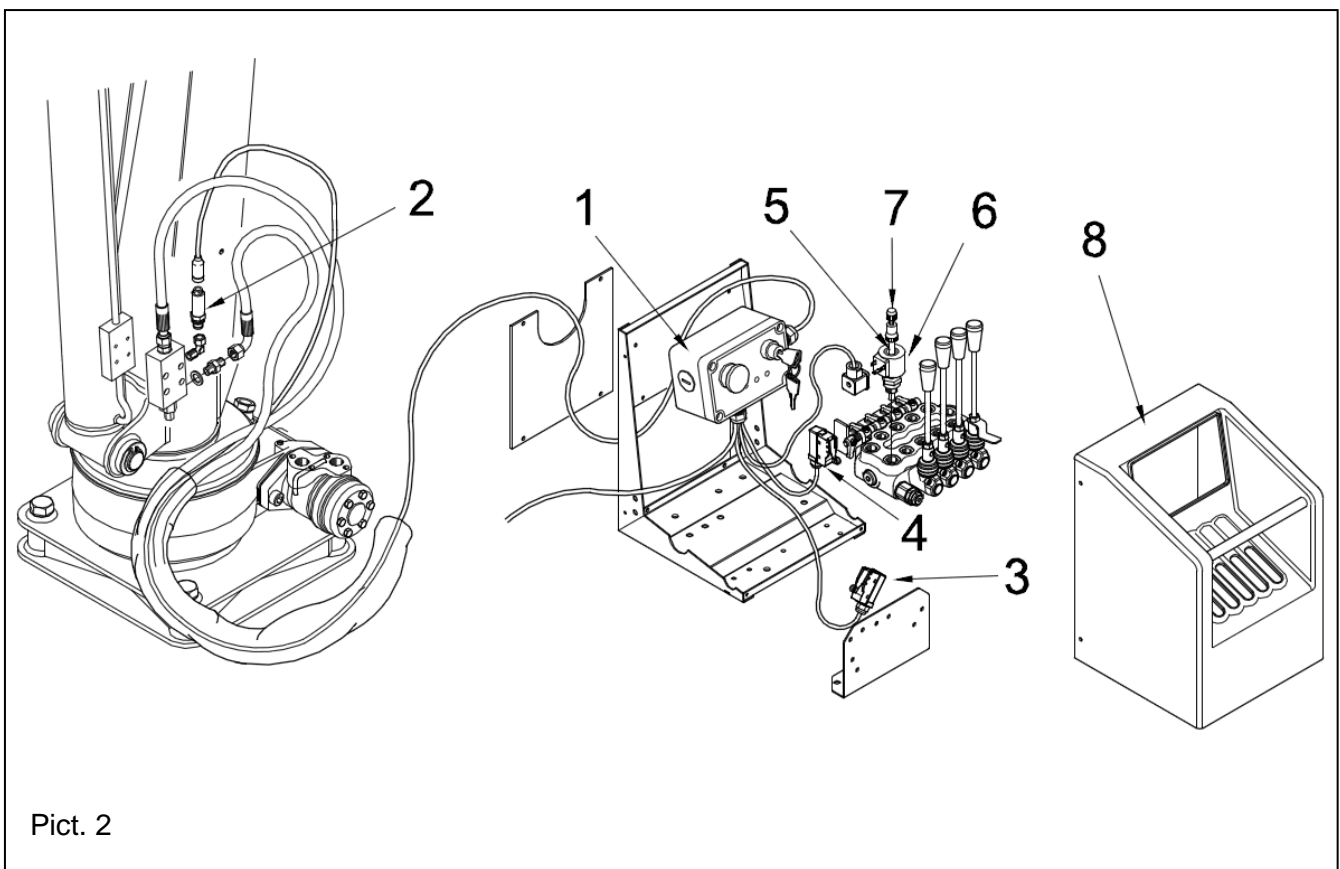

Pict. 2

2.1.1 Control unit box (1)

It is placed on the control station, and contains the electronic cards that process the signals coming from all the input/output devices it is connected with. The front panel carries the key switch and the emergency stop button and allows the visualization of the signals from the electronic card.

2.1.2 Pressure transducer (2)

It is fitted on the over centre valve of the lifting cylinder, to sense the pressure inside the bottom side of the lifting cylinder itself. Its output is a variable electric signal, proportional to the pressure.

2.1.3 Reset micro-switch (extension in) (3)

It is activated by a cam fixed on the control lever of the boom extension, when the extension in function is operated, and resets the lifting moment locking alarm. Retracting the boom extension, the crane is operational.

The activation of this micro-switch (like for the centralized micro-switch, those of the winch function, with the winch stop-end system, and the boom lowering micro-switch, with the SCU) originates a positive voltage signal on the yellow/green wire, that, without remote control, is to be connected to the coil of the electric motor relay, for electrohydraulic cranes. In this case, every time the extension in function is activated, by acting on the lever, the motor pump starts.

The micro-switch contact is N.O. (normally open) when the control lever is in neutral position.

2.1.4 Centralized micro-switch (4)

It prevents the operation of other functions simultaneously with the extension in function in the event of lifting moment locking.

Without additional safety systems, this micro-switch is activated every time any of the control levers are operated, except for the extension in function. For this reason, the cam (**3, Pict. 3**) at the end of the spool of the extension section is made in a way that is doesn't activate the centralized micro-switch when activating the extension in function (type **b, Pict. 3**).

With winch stop-end system, the micro-switch is not activated by the two winch functions. In fact, on winch section of the valve bank, the device for the activation of the centralized micro-switch, represented in picture 3, is not fitted. Instead this is represented in picture 4.

With SCU, it is not activated also by the boom lowering function.

With remote control, it cannot stay in the foreseen position; therefore, it is installed so that it is activated by the boom lowering function, without SCU, or the boom lifting function, with SCU.

The activation of this micro-switch (like for the extension in micro-switch, those of the winch function, with the winch stop-end system, and the boom lowering micro-switch, with the SCU) originates a positive voltage signal on the yellow/green wire, that, without remote control, is to be connected to the coil of the electric motor relay, for electrohydraulic cranes. In this case, when activating any of the functions it is activated by, the motor pump starts.

The micro-switch contact is N.O. (normally open) when the control lever is in neutral position.

ATTENTION

Only when SCU is fitted:

- With the standard valve bank (without remote control), the boom lowering function shall not activate the centralized micro-switch. Therefore, the cam (**3, Pict. 3**) at the end of the spool of the boom lifting/lowering section, is made in a way that is doesn't activate the centralized micro-switch when activating the boom lowering function (type **c, Pict. 3**).
- When a remote control is fitted, the centralized micro-switch is activated by the lever, when carrying out the boom lifting function. Otherwise, in low threshold mode, when trying to lift a load higher than the one allowed, it would be possible to lift it, by carrying out the boom lifting and the extension in functions simultaneously.

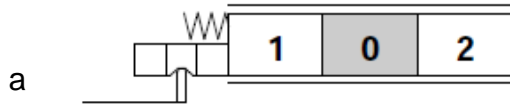
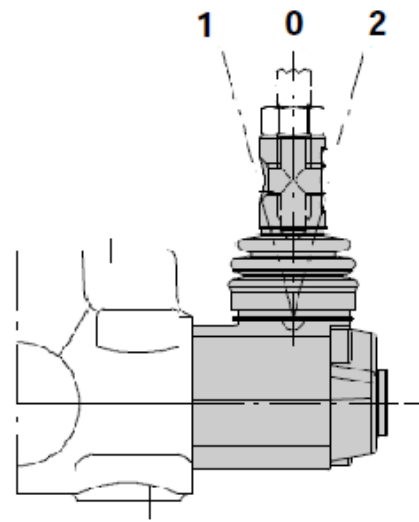
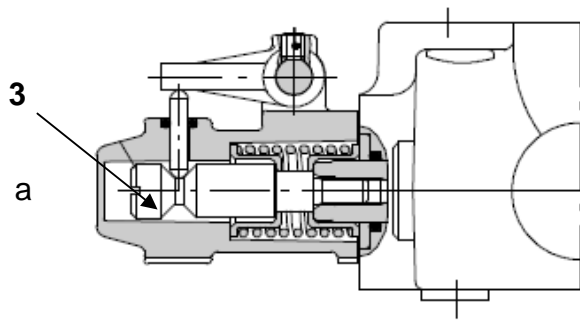

Standard cam: for stabilizers, slewing and boom lifting/lowering (without SCU) functions

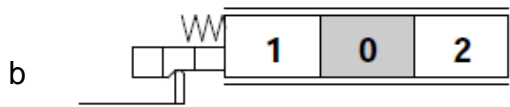

Cam for extension in function

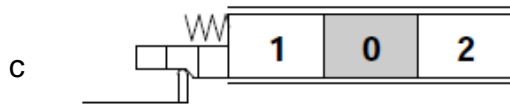

Cam for boom lowering function (with SCU only)

Pict. 3

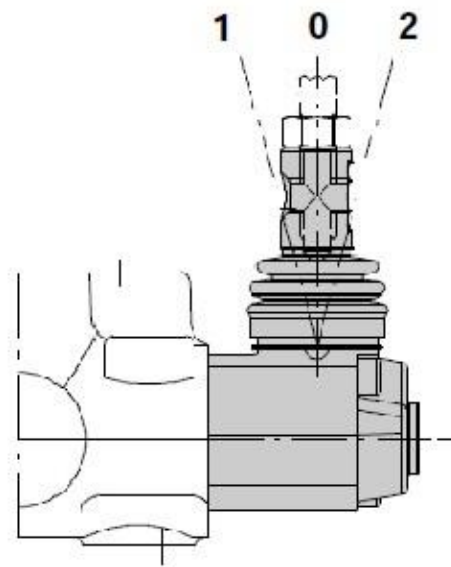
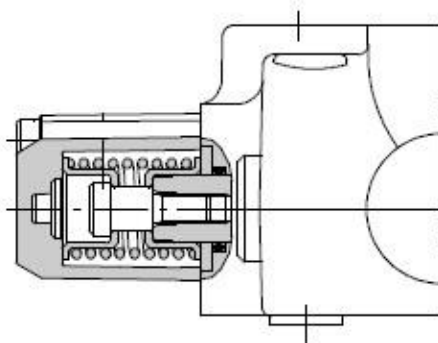

Pict. 4

2.1.5 Dump solenoid valve (Pict. 2)

Its cartridge (5) is screwed in a proper housing of the valve bank, and connects the P port with the T port, when the solenoid is not energized, so that the oil is not available for the crane functions. When the solenoid (6) is energized, the oil flow from P port is available for the crane functions. In conditions lifting moment locking or stop-end the solenoid is not energized, and dumps the oil flow to tank, so that all the crane functions are locked except for the reset ones.

2.1.6 Emergency manual override (7, Pict. 2)

The dump solenoid valve cartridge is equipped with a manual override, the knurled knob is secured, against tampering, with lead seal.

Its purpose is to by-pass the load limiter, when a failure occurs, and it's not possible to exit from the alarm by activating reset functions.

The by-pass is enabled by screwing the knurled knob completely in, after the lead seal has been removed.

In this condition, the crane is to be operated to put down the load and to be brought into transport position, in order to reach the closest assistance workshop.

ATTENTION

The manual by-pass override must only be used in an emergency. It by-passes the load limiter safety system and great attention must be paid by the operator whilst moving the crane in these conditions. Its purpose is solely meant to enable the crane to be stowed in the transport position, reaching the closest authorized workshop and having the load limiter system checked, repaired and sealed again.

2.1.7 Controls cover (8, Pict. 2)

Its purpose is to protect the control system components, and to prevent the control levers being accidentally operated; when its necessary access the components of the control system, it has to be removed.

2.2 Components of the basic load limiter (Pict. 5)

- 1) ON/OFF removable key
- 2) Red emergency stop button
- 3) Green LED (**ON**) (load limiter turned ON)
- 4) Yellow LED (**90%**) (forewarning)
- 5) Red LED (**ALARM**) (lifting moment locking alarm)
- 6) Micro-switches
- 7) Dump valve solenoid connector
- 8) Supply cable
- 9) Pressure transducer
- 10) Main electronic card (signal processing and internal LEDs signalling)
- 11) Panel board (external LEDs signalling and components connection)
- 12) Connection wiring between the boards
- 13) Connection wiring between the boards
- 14) Winch wiring (optional)

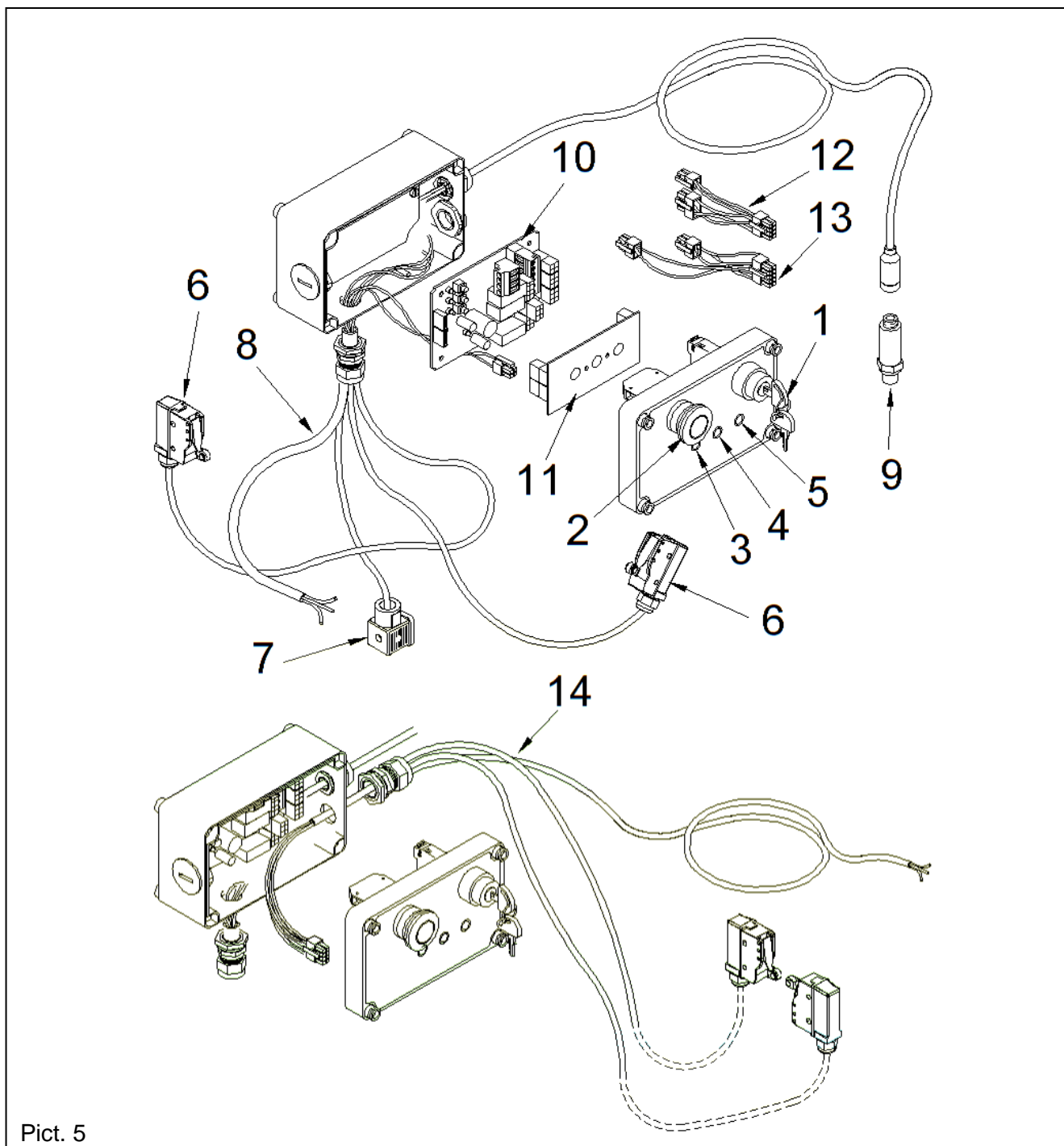

2.3 Cards layout and parts (Pict. 6)

- SW1) Start/finish calibration button
- SW2) Low threshold calibration button
- SW3) High threshold calibration button
- D3) green LED (voltage supply to the card, when lit up)
- D10) green LED (voltage supply to the pressure transducer, when lit up)
- D19) green LED (used in calibration, and for signalling errors related to the pressure transducer)
- D20) red LED (calibration phase and alarm condition signalling)
- D21) yellow LED (used in calibration, and for signalling errors)
- LS1) Relay 1 (it controls the dump valve solenoid)
- LS2) Relay 2 (it controls the motor pump relay)
- LS3) Duplicated relays 1 and 2 (for safety)
- J4) Connection with panel board
- J6) Connection with panel board
- J7) Connector for analogue signal input (not available; all the inputs are used for card internal checks)
- J9) Connection with panel board
- J10) Connection with panel board
- J11) Pressure transducer connector
- J12) RS-232 connector
- J14) Calibration jumper
- J15) ON-OFF winch pull limiter
- J20) Ground connection
- J100) Connection with main board
- J101) Connection with main board
- J104) Voltage supply connector J105)
- Dump valve solenoid connector
- J109) Extension in reset micro-switch connector
- J110) Centralized micro-switch connector
- J120) Winch wiring connector
- J121) SCU wiring connector
- J122) Boom lowering micro-switch connector (for SCU)
- J123) Slew limiter connector
- RV1) self-restoring poli-switch
- DL1) red LED (ALARM)
- DL2) yellow LED (90%)
- DL3) green LED (ON)

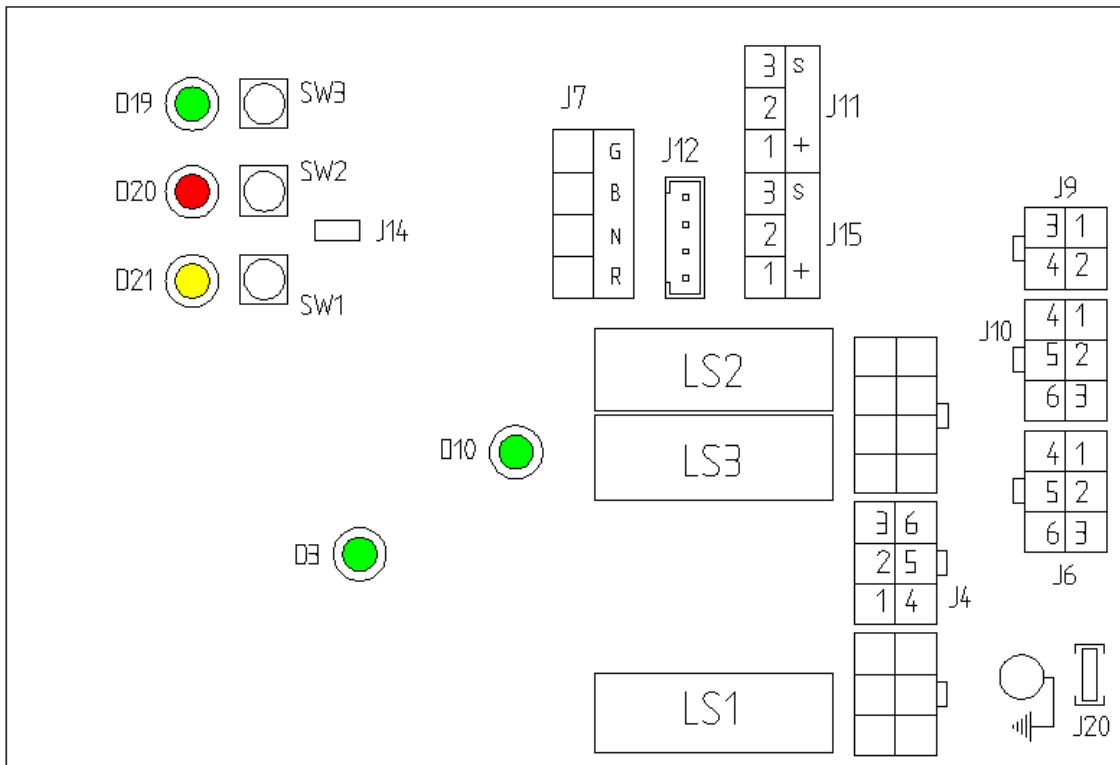
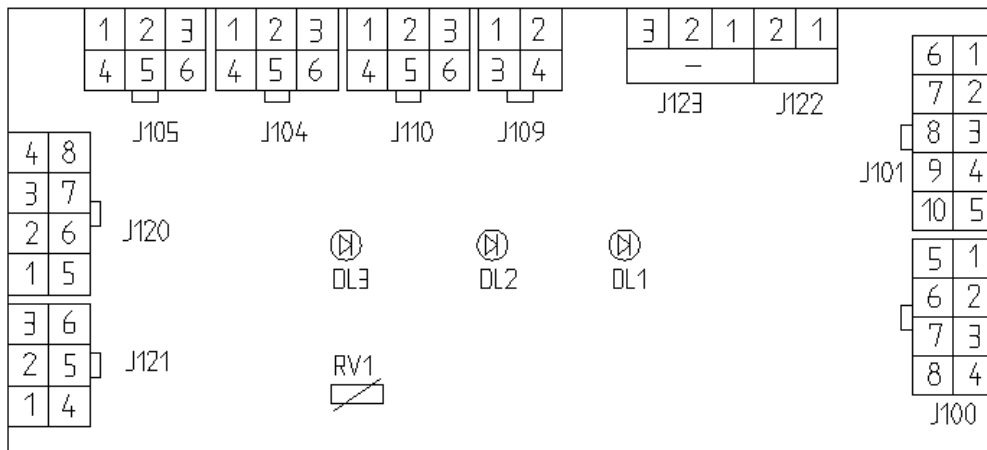

Pict. 6

3 Electrical connection of the system

Permitted supply voltage range: 9 to 33V

Permitted working temperature range: -40 to +70°C

The only connections to be carried out from the crane installer are the following:

- a) Brown wire marked "+", to battery (+)
- b) Blue wire marked "-", to battery (-)
- c) Yellow/green wire, to the coil of the electric motor relay, for electrohydraulic cranes without remote control only. This wire gives a positive voltage on the terminal of the coil, every time a function is operated.

ATTENTION

The yellow/green wire has to be cut and insulated in the following cases:

- PTO driven cranes (H version)
- Cranes equipped with remote control (both H and E versions)

IMPORTANT

It is strictly forbidden to carry out welding operations whilst the LLD system is turned ON. The system must be switched off and the wires brown (+) and blue (-) disconnected before welding or operating power tools.

4 Check of the load limiter system functionality

4.1 Protections of the system

The system performs, every time it's turned ON, a self-test on the safety functions, lasting a few seconds. During the self-test, in addition to the green LED, also the red LED lights up, and the crane is locked. During the self-test, the levers of the valve bank are not to be operated.

At the end of the self-test, the red LED light turns OFF, indicating that the crane is operational.

By continuous monitoring, the electronic card can detect failures of the card itself, of the pressure transducer, and of the micro-switches on the valve bank, locking the crane. At the same time, the failure is signalled by different error codes, according to the nature of the failure.

Having a lever activated when turning the system ON triggers the alarm because it could be due to any of the control levers stuck in the activation position, or to a reset micro-switch contact stuck closed, and that would bypass a possible alarm or stop-end condition.

The electronic card is protected against:

- polarity inversion
- excess of input voltage, according to EN 60204 (by means of a self-restoring poli-switch integrated in the panel card)
- excess of output voltage, excess current loads, and short circuit of the outputs according to EN 60204 (by means of components integrated in the main card)
- disconnection or shorting of the pressure transducer wires

4.2 Calibration of the load limiter system (Pict. 7)

4.2.1 Preparation for the setting

- 1) With reference to the crane load chart, prepare a load achieved by increasing the load on the last hydraulic extension, at the maximum outreach (R) allowed by $8+0.5 \times R$ %.
- 2) Remove the plastic protection from the control station.
- 3) Turn the load limiter OFF.
- 4) Open the load limiter box, removing the seals and the four screws.

4.2.2 Calibration procedure

- 1) Insert the bridge connector (placed inside the box, in a small nylon envelope) on jumper **J14**.
- 2) Switch the load limiter ON again by the key switch. The green LED **D3** will light up. Even if the red LED **D20** is lit up, go on with the procedure.
- 3) Push the button **SW1**; yellow LED **D21** will light up, while the red LED **D20** blinks. In this condition, the dump valve solenoid should be energized. Otherwise, it's necessary to activate its cartridge hydraulically, by screwing the manual override in.
- 4) Lift the load previously prepared, and bring it, with the boom in horizontal position, at the maximum hydraulic outreach.
- 5) Push the button **SW3**; the green LED **D19** will flash shortly.
- 6) Push the button **SW1**, to exit from the calibration procedure; the yellow LED **D21** will light OFF. The red LED **D20** stays ON still.
- 7) Retract the boom extension and check that the red LED **D20** lights OFF.
- 8) Turn the system OFF to store the setting.
- 9) Remove the bridge from jumper **J14**, and store it inside the box as found.

4.2.3 Checks

- 1) Switch the load limiter ON again, and wait until the self-test is finished.
- 2) Telescope out and in the boom extensions a few times and check that the yellow and red lamps on the frontal panel light up according to the outreach.

4.2.4 Sealing the system

- 1) Close the box, and apply metal wire and seal on two screws of the cover, that is drilled for this purpose.
- 2) In case, restore the sealing of the manual operator of the dump solenoid valve, if it has been previously removed.

IMPORTANT

Never switch the supply voltage OFF, during the calibration procedure, to avoid its failure.

ATTENTION

The calibration may prove difficult or impossible if the pressure transducer is faulty, or when the supply voltage disappears, even for a while, during the procedure.

This is shown from the flashings of green lamp D19.

If, during the calibration, the yellow lamp D21 flashes, look at chapt. 7 and proceed accordingly.

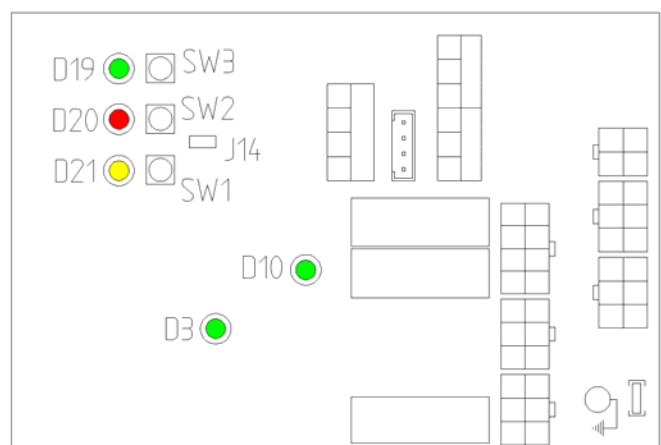

Pict. 7

4.3 Safety checks

With the load limiter turned ON:

- In lifting moment locking or stop-end alarm condition, when activating a reset function, no other crane function must be allowed at the same time.
- In normal condition, disconnect the pressure transducer from its cable connector: this shall immediately lock the crane, the yellow LED blinks, and none of the crane functions is allowed.

4.4 Check of the emergency button functionality

Locate this red button on the front cover of the load limiter box. Bring the load limiter system operational, then push the button and check that none of the crane functions can be operated. This button has a mechanical lock-in, for disengaging it and operate the crane again, the ring underneath the button knob has to be turned clockwise.

4.5 Setting of the over centre valve on the lifting cylinder

This valve is already pre-set at the factory. Therefore, its setting is prohibited, unless the valve needs to be replaced or its setting has changed.

Should this setting be necessary:

- Prepare a load 30% greater than nominal one at chosen outreach.
- Tight on the adjustment screw on the valve so that is fully closed.
- Remove the distributor cover and access to the emergency manual operator
- Bypass the load limiter acting on the emergency override, lift the load and bring the boom system horizontal, then extend until the chosen outreach is achieved
- Now carefully and slowly unscrew the adjustment screw on the valve until the boom starts very slowly to lower. This point is the correct setting. Fix the screw in this position tightening its lock nut.
- With load suspended, switch the key off, disengage the PTO and check that activating the boom lowering function, the boom does not lower.
- Unscrew the emergency override bringing to the normal position, secure with wire and seal, refit the distributor cover.

4.6 Purpose and meaning of the front cover lamps (Pict. 8)

The three LED lamps on the front cover indicate the state of the load limiter system and also show failures or anomalies by means of coded series of flashings.

- 1) Green lamp "ON" lit up still = supply voltage to the system
- 2) Yellow lamp "90%" lit up still = load at 90% of rated value
- 3) Red lamp "ALARM" lit up still = Rated capacity exceeded, and crane locked except for the reset functions

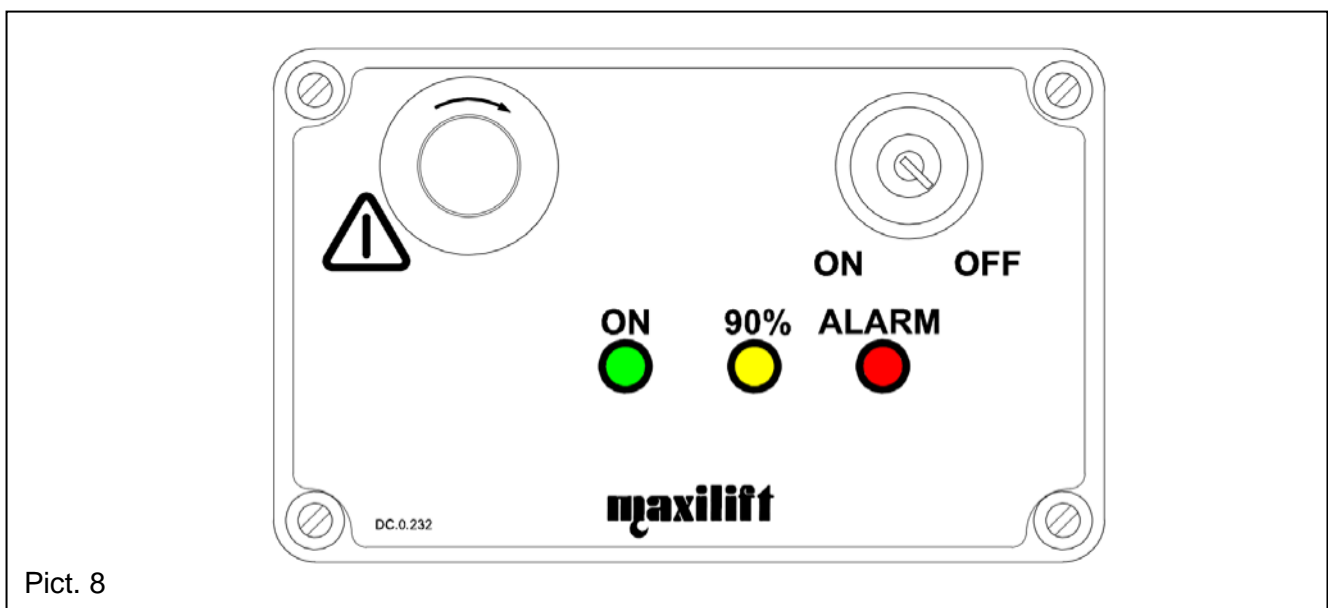

Pict. 8

Table of the error code messages through the LEDs of the front panel (Pict. 8)

Code	Yellow LED – 90%	Red LED – ALARM	Message	
E0	OFF	OFF	No errors	
E1	Flashing	Flashing	Faulty electronic card	●
E2	OFF	Flashing	Check connection of micro-switches, or faulty electronic card	●
E3	ON	Flashing	Short circuit on solenoid valve or its cable, or faulty electronic card	●
E4	Flashing	OFF	Check pressure transducer or its connection	●
E5	Flashing	ON	Low supply voltage	
E6	OFF	ON	Lifting moment locking alarm – crane locked	
E7	ON	OFF	Lifting moment locking forewarning	
E8	ON	ON	Winch stop-end micro-switches activated or intervention of the winch strain limiter	
E9	OFF	Flashing slowly	Negative voltage supply line disconnected or interrupted	
● Anomalies to be reported to authorized workshops				

4.7 Error code messages from the LEDs on the electronic card (Pict. 7)

Two types of error code may occur:

- Errors related to the pressure transducer – indicated by the green LED D19
- Errors related to the electronic card – indicated by the yellow LED D21

Errors on pressure transducer – LED D19 green		Errors on electronic cards – LED D21 yellow	
Number of flashes	Message	Number of flashes	Message
-	No errors	-	No errors
1	Error on pressure transducer line (see 7.2.1)	1	Faulty circuit card - replace
		2	Faulty circuit card - replace
5	Signal from pressure transducer too low (see 7.2.2)	3	Check connection to the solenoid valve
7	System calibration incorrectly recorded	4	Check connections from micro-switches to the card (refer diagram). Check micro-switches
		5	Replace the card

NOTE

The error code of the front panel must be related with the one given by the LEDs on the electronic card, by the same anomaly.

5 Safety tips, checks and maintenance

5.1 Safety tips

- The load limiter system requires a voltage supply directly from the battery.
- Always disconnect the voltage supply before working on the wiring or replacing components.
- Always disconnect the voltage supply and ground connections before carrying out welding on the crane or on the vehicle.
- If necessary for the nature of the crane operations, further protection for the wiring and the pressure transducer should be installed.
- Always keep any source of heat or electro-magnetic fields far away from the electronic box, from its wiring and pressure transducer.
- Never submit, during cleaning operations, the electronic box and the pressure transducer to direct sprays of water, chemical cleaning products, hot steam etc.
- Never drill holes or cut the load limiter box.

5.2 Checks and maintenance

The load limiter does not require any regular maintenance during its working life.

The load limiter system is a safety device, it's important to perform the following checks:

5.2.1 Checks after the installation of the load limiter on the crane

- Correct battery voltage, between 9 and 30 V
- Proper closure and tightening of the load limiter box and relevant connectors
- Switching OFF the master switch should also turn OFF the load limiter

5.2.2 Checks before every working session with the crane

- Good conditions of wires, hoses, connectors, electronic box and pressure gauge
- Lift the boom until the end-stroke of the lifting cylinder is achieved, checking that the crane gets locked. This will ensure that the pressure transducer is able to give the signal to lock the crane.

5.2.3 Special maintenance

Any other operation not hereby described is outside normal maintenance and shall be reserved to specialized workmanship. Apply to **Penny Hydraulics** for further information.

6 Wiring diagrams

The LME04 load limiter has been developed to be integrated, in a modular way, with all the possible foreseen safety systems, listed below:

- Winch stop-end system
- Slew limiter
- SCU
- Winch pull limiter

On the connectors foreseen for the connection of these devices, the system, in the basic version, has bridges bypassing the relevant systems, so that any of the safety systems can be added singly, independently from the others.

6.1 Connection diagram of the basic load limiter (Pict. 9)

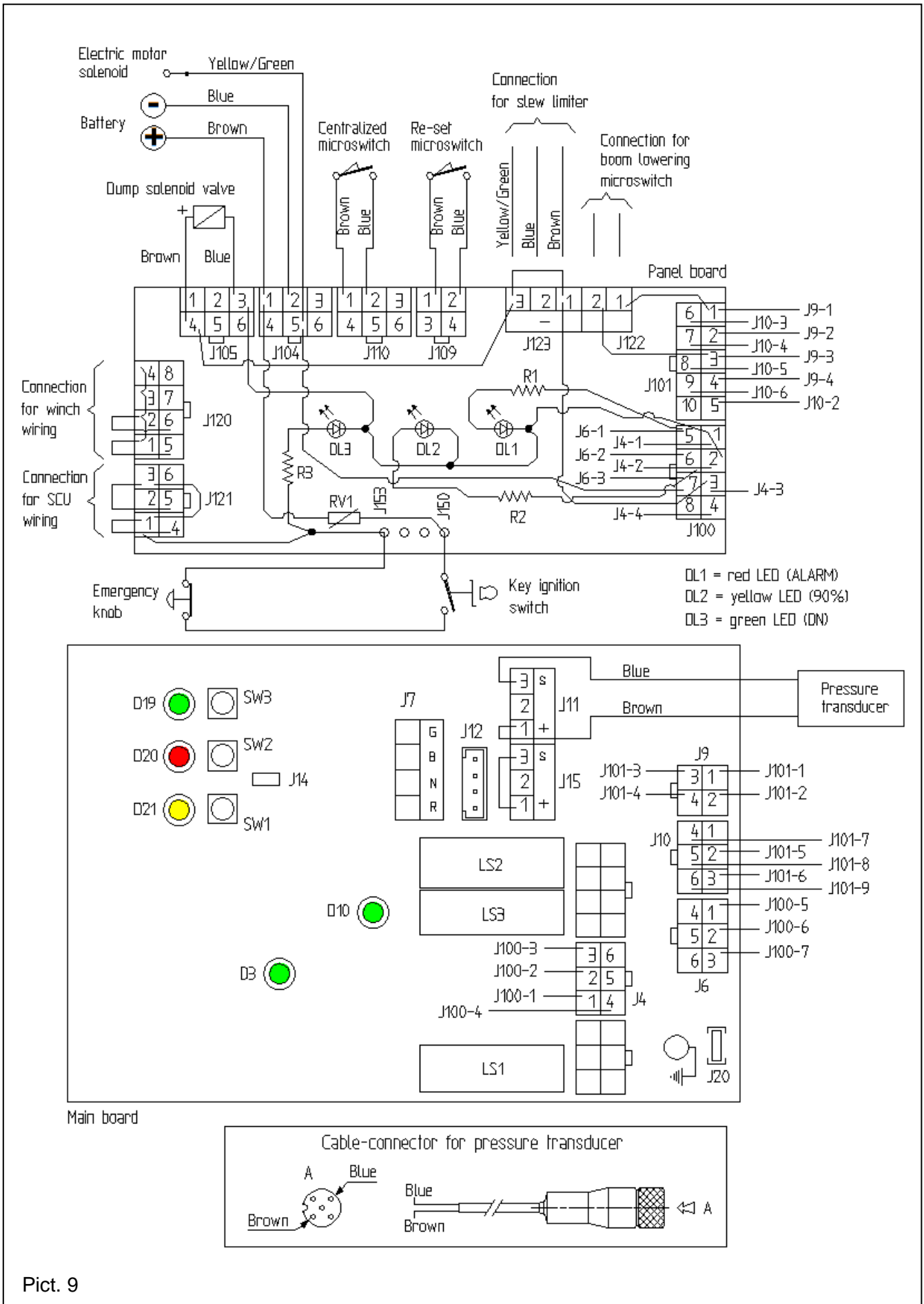

Pict. 9

6.2 Winch stop-end system wiring diagram (Pict. 10)

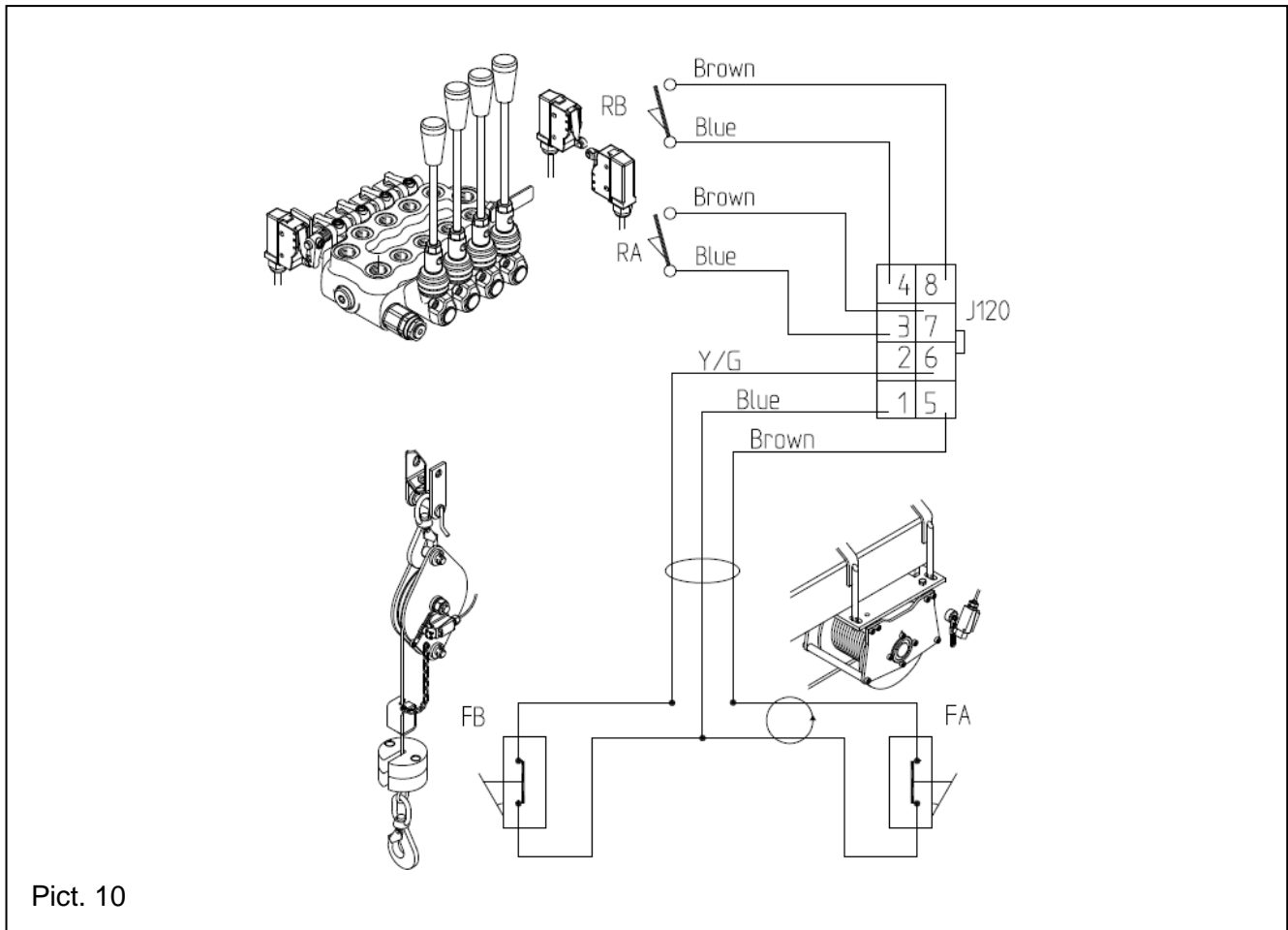

FA = Limit switch on winch drum (contact closed when operational)

FB = Limit switch on pulley (contact closed when operational)

RA = Winch up micro-switch (reset FA; N.O. connected)

RB = Winch down micro-switch (reset FB; N.O. connected)

6.2.1 Behaviour of the system

The intervention of FA or FB is signalled by error code E8.

When FB switches, the allowed functions are (singly or simultaneously):

- Winch down
- Extension in

When FA switches, the allowed function is:

- Winch up

The micro-switches RA and RB are monitored by the system, in the following conditions:

- When turning the system ON, by the self-test, in order to avoid that one of them, should its contact be stuck closed (control lever stuck in activation position, or problem on the contact, like water ingress or stuck actuator), keeps the relevant limit switch bypassed.
- Continuously, by checking that the contacts of the two micro-switches are not both closed; if they are both closed.

NOTE

The winch functions shall never activate the centralized micro-switch, since they are controlled by the relevant micro-switches. Therefore, on the winch section of the valve bank, the device for the activation of the centralized micro-switch shall not be fitted (see **Pict. 4**).

6.3 Slew limiter wiring diagram (Pict. 11)

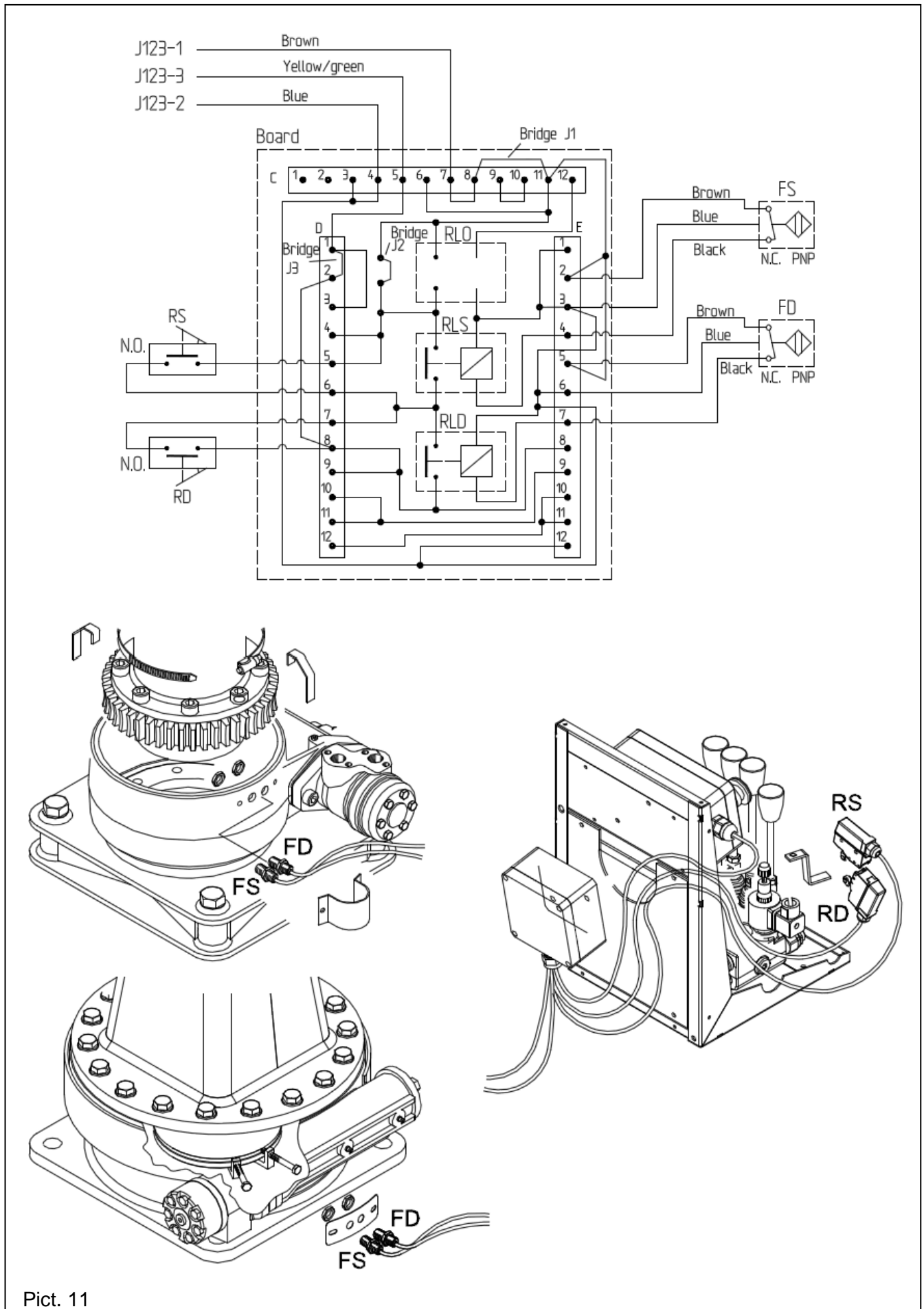

Pict. 11

FS = Rotation left proximity limit switch
FD = Rotation right proximity limit switch
RS = Rotation right micro-switch (reset FS; N.O. connected)
RD = Rotation left micro-switch (reset FD; N.O. connected)
RLS = Relay for FS (N.O. connected)
RLD = Relay for FD (N.O. connected)

6.3.1 Behaviour of the system

The stop-end system is monitored via sensors and by a connection card that carries information to two relays that are necessary to handle the signals from the two proximity limit switches. The card is placed inside a shunt box fixed in the rear of the control station.

This card takes the positive voltage supply, on the brown wire, from the solenoid valve enabling signal (from the LME04 panel board). When the circuit is closed, the enabling signal reaches the solenoid, through the yellow/green wire.

The connection of the card to the negative, through the blue wire, is necessary for supplying the proximity switches and the relays.

Since this circuit is in series connected to the line supplying the load limiter solenoid, its function depends on the solenoid enabling signal. None of the proximity limit switches or reset micro-switches are monitored by the load limiter system. This means that:

- The intervention of the limit switches is not signalled by any of the error codes on the front panel.
- On reset micro-switches RS and RD, there's no monitoring by the load limiter in order to check if their contacts are closed, when turning the system ON (problem on the contact, like water ingress or stuck actuator); if one of the contacts is closed, the relevant limit switch is by-passed. The load limiter doesn't check if, during operation, both contacts are closed simultaneously.

Each proximity limit switches FS and FD supplies the solenoid of the relevant relay by closing its contact, when the relevant metal stop-end target (protected inside the casing of the slewing mechanism) is not in front of the proximity itself. In this condition, the LED of the proximity is lit up. The circuit opens when, at least, one of the proximity limit switches detects the target, its LED lights off, and the relay contact opens.

When FS switches, all the functions are locked, except for rotation right.

When FD switches, all the functions are locked, except for rotation left.

IMPORTANT 

Since this stop-end system has no monitoring, it's important to check frequently its functionality.

6.4 SCU wiring diagram for crane with main stabilizer, without supplementary stabilizer (Pict. 12)

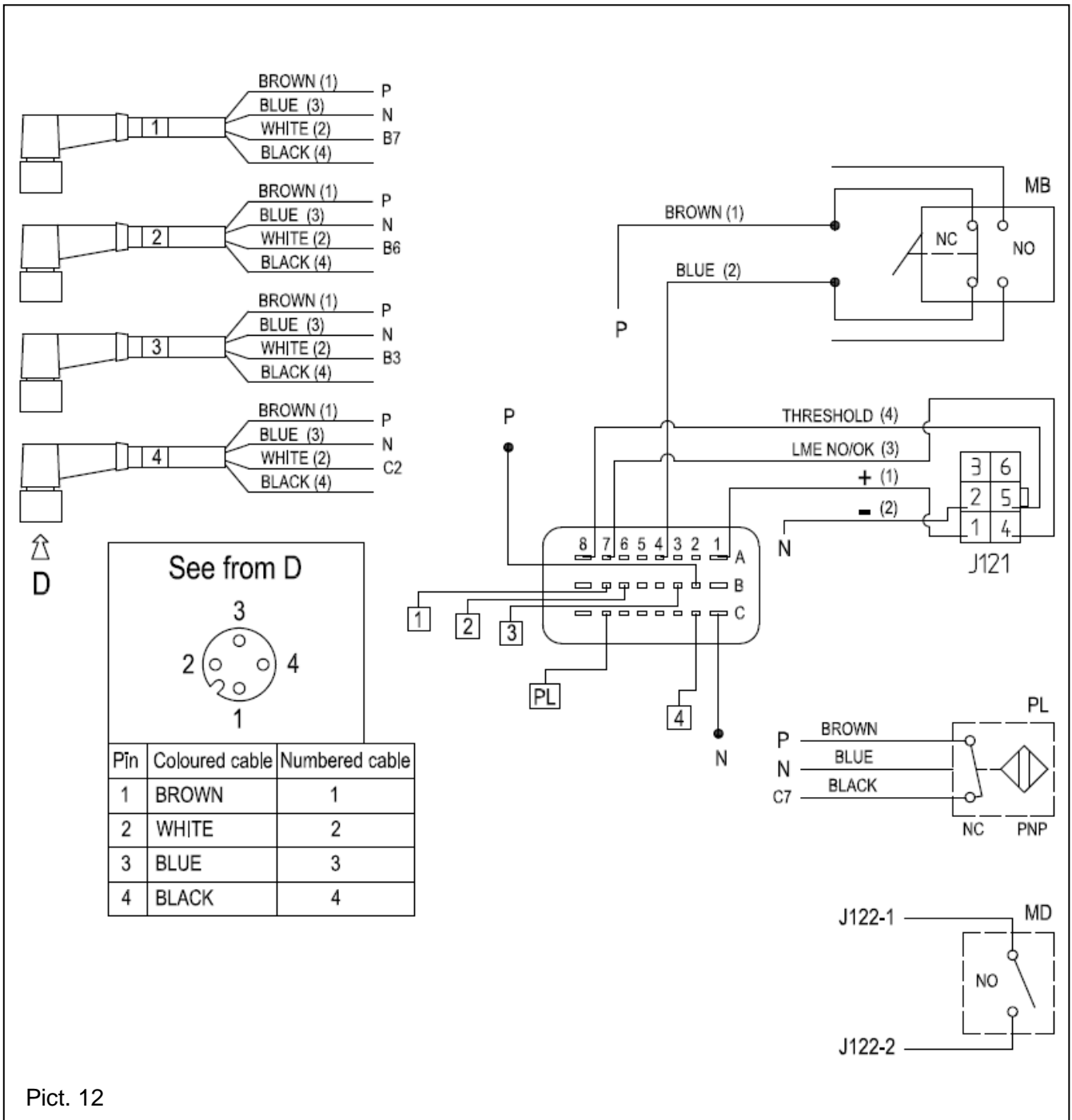

- P = Centre of the positive supply signals (square wave)
- N = Centre of all the grounds
- MB = Boom stowage micro-switch (on crane)
- PL = Proximity on the stabilizer function lever (on valve bank)
- MD = Boom lowering micro-switch (on valve bank)
- 1-2-3-4 = 4-core cables with M12x1 connector for the four stability sensors

6.5 SCU wiring diagram for crane with main stabilizer and supplementary stabilizer (Pict. 13)

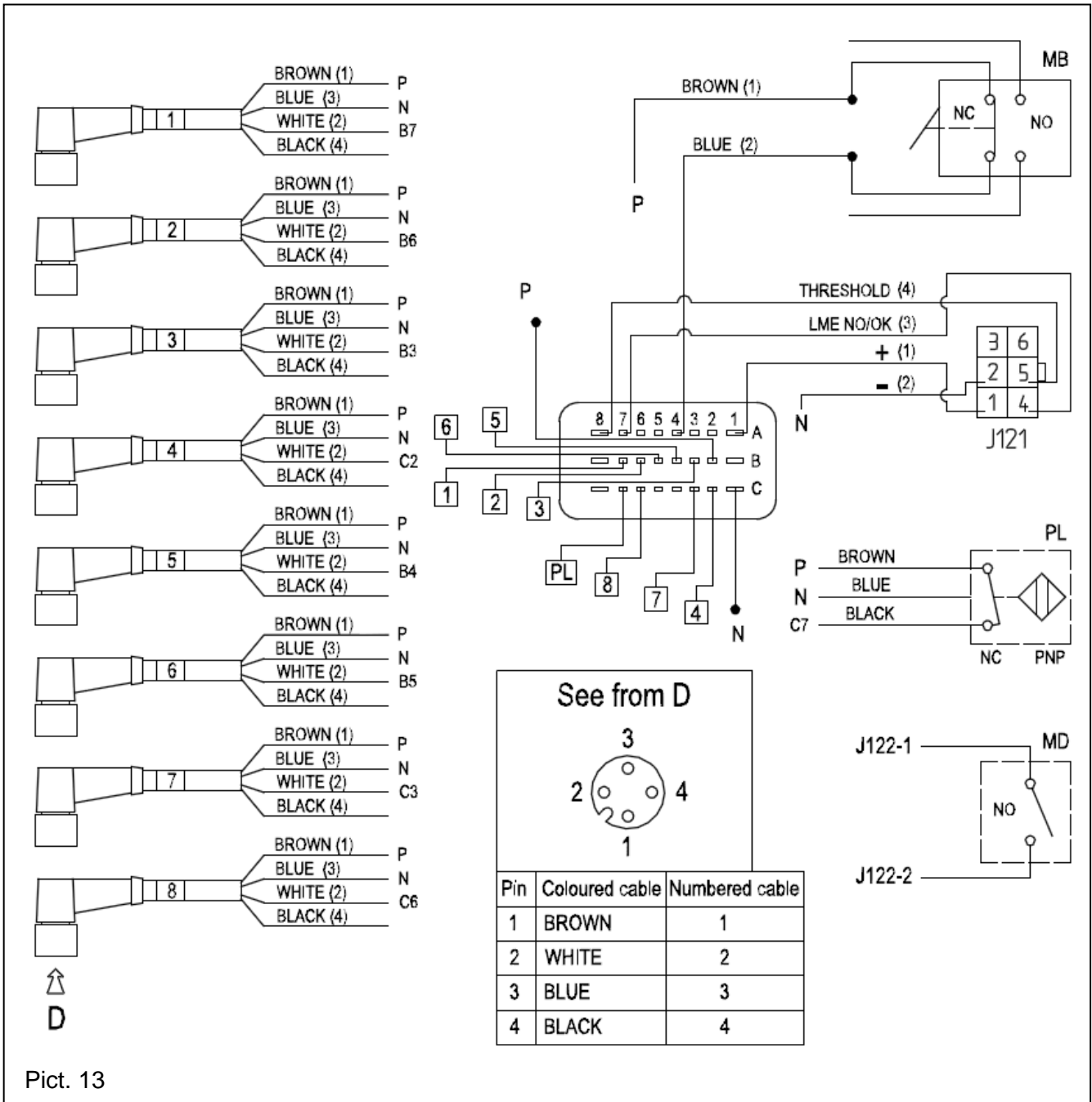

P = Centre of the positive supply signals (square wave)

N = Centre of all the grounds

MB = Boom stowage micro-switch (on crane)

PL = Proximity on the stabilizer function lever (on valve bank)

MD = Boom lowering micro-switch (on valve bank)

1-2-3-4-5-6-7-8 = 4-core cables with M12x1 connector for the eight stability sensors

6.6 Winch pull limiter wiring diagram (Pict. 14)

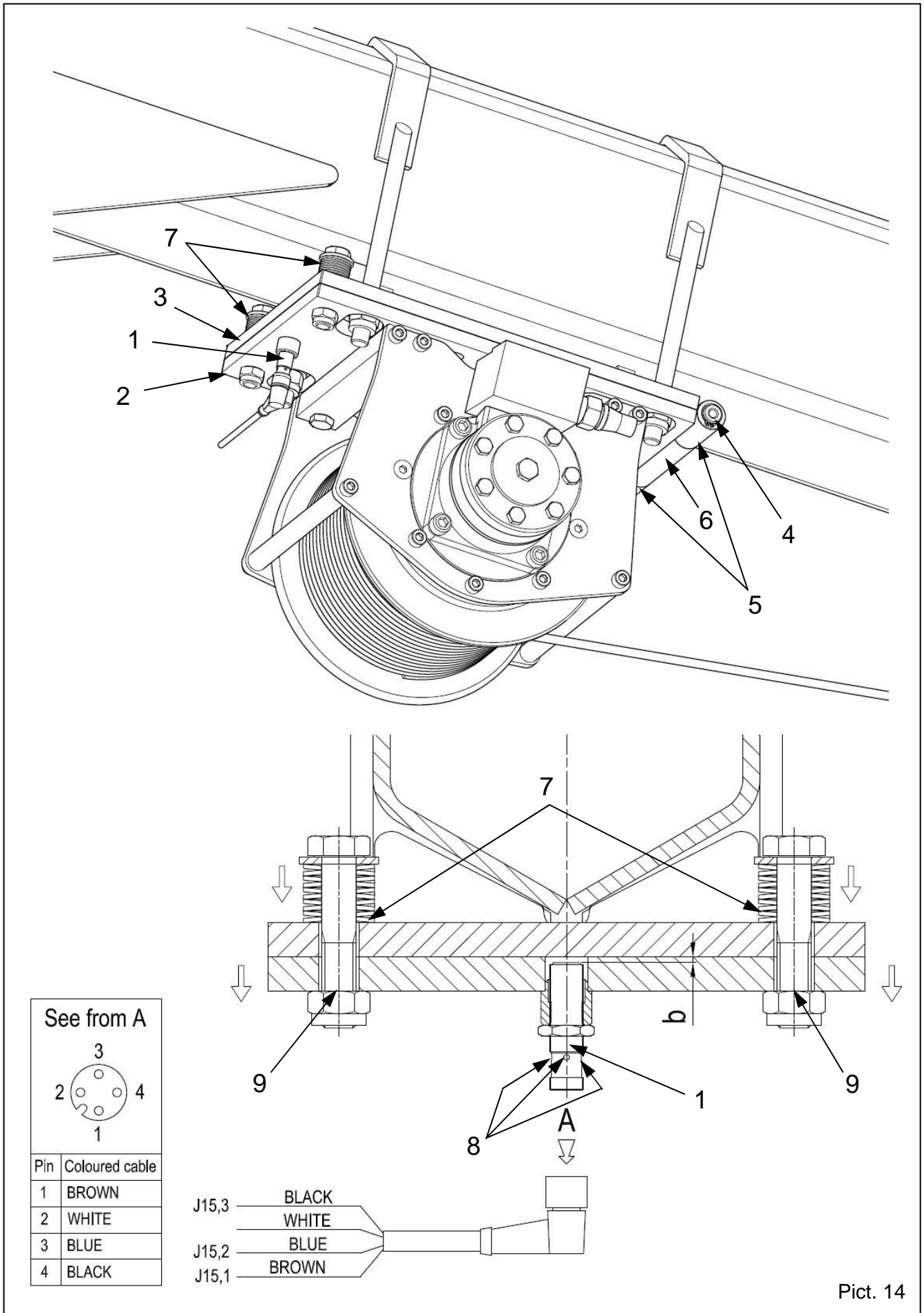

6.6.1 Behaviour of the system

The intervention of the pull limiter takes place when the load exceeds the maximum lifting capacity indicated for the winch, and is signalled by the error code E8.

In this alarm condition, the allowed functions are (singly or simultaneously):

- Winch down
- Extension in

This device requires the presence of the winch stop-end system.

The signal of the pull limiter is of the ON-OFF type, and is handled by a PNP-proximity (1) screwed on a plate (2) that moves away, because of the winch pull, from a plate (3) that is fixed to the crane arm. The two plates are provided with bushes welded in the front, where they are hinged to each other by means of the articulation pin (4). The two bushes (5) belong to the plate (3), while the bush (6) belongs to the plate (2). The plate (2) can therefore rotate, in respect of the plate (3), around the axle of the pin (4). Hence, it's possible to detect the clearance that takes place in the rear side, opposed by the resistance of two packs (7) of disc springs.

From the point of view of the signal, the intervention of the pull limiter takes place when the nominal voltage signal (corresponding to the voltage supply of the system) disappears from the black wire connected to the terminal 3 of connector J15. This happens when the distance (b) between the front surface of the proximity and the metal surface of the plate (3) exceeds 4 mm, and so the LED (8) of the proximity goes off. These LEDs are lit up still, in normal operating conditions. The proximity is connected in such a way that it is a Normally Open circuit.

The setting of the whole device depends on the pre-loading of the springs, achieved by the tightening of the bolts (9), and the distance (b).

As far as the adjustment of the proximity is concerned, it is useful to remember that its thread is M12x1. Therefore, in order to evaluate its distance from the lower surface of the plate (3), it is necessary to consider that, if its frontal surface touches the surface of the plate (3), it will move 1 mm away, by unscrewing one turn.

7 Troubleshooting

7.1 Table of possible faults

Problem	Error message on card	Likely fault	Solution
None of the crane functions work	All the LEDs are OFF	No voltage supply or inverted polarity Faulty emergency button Faulty key switch Faulty electronic card	Check battery connections Replace Replace Replace
None of the crane functions work	The relays work unsteadily, and the LEDs are flickering	Low voltage supply Damaged electronic card	Check battery conditions Replace
None of the crane functions work	Green LED D19 flashes	Pressure transducer error	Refer to paragraphs 4.7 e 7.2.
None of the crane functions work	Yellow LED D21 flashes	Electronic card error	Refer to paragraphs 4.7
None of the crane functions work	Red LED D20 lit up steady	Lifting moment locking Incorrect calibration Defective pressure transducer	Retract boom extension Repeat calibration Refer to paragraph 7.3
None of the crane functions work	Green LED D3 OFF	Electronic card not supplied Damaged electronic card	Check connections to voltage supply Replace
None of the crane functions work	Green LED D10 OFF	Damaged electronic card	Replace
None of the crane functions work	Yellow LED D21 giving 4 flashes	Moisture or water inside micro-switch Moisture on one of the cards Micro-switches N.C. connected instead of N.O.	Open micro-switch to drain away water or dry moisture Replace micro-switch Dry card (if it doesn't solve, replace) Connect N.O.

7.2 Testing the pressure transducer with error code E4 (transducer connected and load limiter turned ON)

It's possible to perform a test to verify if the problem is due to a poor connection, or to an incorrect signal.

Connect a digital multimeter, 20 V c.c. scale, between terminal 3 of connector J11 and the negative on the battery.

7.2.1 Internal error code: Green LED D19 = 1 flash (Error on pressure transducer line)

Should the red LED D20 be lit up, this means that the system was previously in overload condition, and has not been reset.

If the voltage displayed by the multimeter is 0 V, then the pressure transducer line is interrupted, and this could be due to:

- the cable of the pressure transducer has a broken wire
- one of the terminals of connector J11 oxidized
- one of the wires connected to J11 has a poor connection
- one of the pins of the pressure transducer oxidized
- one of the pins of the connector on the pressure transducer cable oxidized
- damaged card (if all the connections are good)

7.2.2 Internal error code: Green LED D19 = 5 flashes (Signal from pressure transducer too low)

If the voltage displayed by the multimeter is below 0.8 V, there is a fault. If this voltage is within the range 0 V ÷ 0.8 V (but not 0 V!), the pressure transducer or the electronic card is faulty, and must be replaced.

EXPLANATION

The voltage read between these two terminals, in normal conditions, is above 0.8 V, and increases proportionally with the signal from the pressure transducer, when the pressure increases. It has to be 0.8 V (or little more) at 0 bar.

If the signal is too low, the voltage read at 0 bar can be for example 0.7 V. This is the reason why the error code description is "signal too low". It can also happen that increasing the pressure applied to the pressure transducer, by lifting a load, makes the voltage increase above 0.8 V, eliminating this way the error code. But as soon as the pressure drops again the error code returns. It can also be that the voltage remains below 0.8 V in a range of pressure between 0 bar and 100 bar, and increases only above 100 bar.

This alarm condition avoids the lifting moment locking alarm occurring for a load configuration higher than the one originally set for the intervention of the load limiter.

In order to establish which of the two components is defective, test the transducer disconnected from the load limiter, as described in paragraph 7.3.

7.3 Testing the pressure transducer disconnected from the load limiter

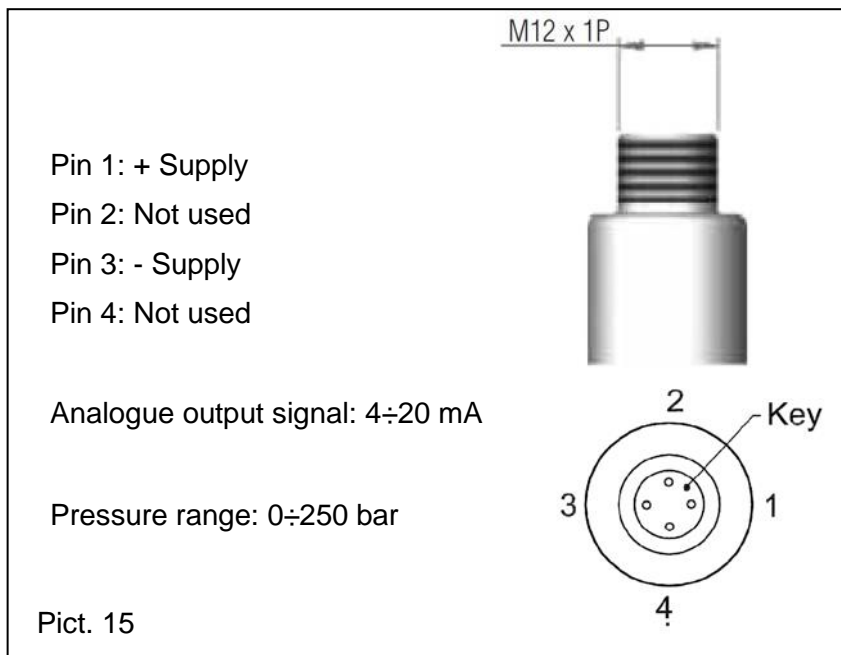

Supply the transducer with a voltage within 8 to 30 V, and connect a Multimeter (mA DC), on the positive or negative supply line in series, in order to measure the current in mA. Theoretically, the current values to be read should be **4 mA** at **0 bar** and **20 mA** at **250 bar**. In order to achieve values in between, it has to be considered that the relationship is linear (a straight line). The tolerance is $\pm 0.5\%$ of the analogue output signal range is 16 mA (20-4), therefore 0.08 mA. This means that, at 0 bar, can be read a current from 3.92 mA to 4.08 mA, while at 250 bar, can be read a current from 19.92 mA to 20.08 mA.

Example table:

Pressure bar	Direct current		
	Nominal mA	min. mA	max. mA
0	4	3.92	4.08
50	7.2	7.12	7.28
100	10.4	10.32	10.48
150	13.6	13.52	13.68
200	16.8	16.72	16.88
250	20	19.92	20.08

8 Stability control unit SCU

8.1 Operating logic

The SCU system is a device that monitors the stabilization and interacts with the load limiter, which has two alarm thresholds. When turning the system ON from the control panel, any function of the crane is allowed, in low threshold mode of the load limiter, signalled by the yellow LED (9) on the SCU panel (Pict. 16). The low threshold is set to prevent the vehicle overturning, even if the stabilizers are not set.

In order to achieve the full lifting capacity (high threshold mode), it's necessary to fully set the stabilizers (completely extended out and to the ground), so that all the stability sensors are activated, and the LED (9) signalling the low threshold mode lights off. Any activated sensor is signalled by the relevant LED lit up on the SCU panel (e.g.: extension sensor - LED 1, ground sensor - LED 2, etc...). All the stability sensors are continuously monitored, and the system returns in low threshold mode in the following three conditions:

- When at least one of the extension sensors is no longer activated (independently from the number of outriggers)
- If the outrigger is only one, when two ground sensors are no longer activated.
- If the outriggers are two, when three ground sensors are no longer activated.

When turning the system ON, with the crane completely folded, it performs an initial self-test on the stability sensors (in order to avoid that the sensors are activated even when the stabilizer is closed). If the system detects at least one of the stability sensors activated, all the crane functions are locked except for the one of the stabilizers, and the fault is signalled by flashing of the LED related to the activated sensor, and of the yellow LED (9). Even after the activated sensor has been deactivated (or its functionality has been restored), so that its LED doesn't flash anymore, the yellow LED (9) still flashes keeping the crane functions, except for the one of the stabilizers, locked. Therefore, it's necessary to switch the system OFF and ON from the load limiter panel.

Lifting the boom from the condition of crane completely folded, the green LED (10) lights up signalling that the boom is in working position. In this condition, the stabilizers function is locked. Further, switching the system OFF and ON in this condition, the threshold mode of the load limiter is the one of the system before it was switched OFF.

When the system is switched OFF with the boom completely folded (transport position), switching the system ON again, if the stabilizers are completely or partially positioned the initial self-test detects that the sensors are activated. In order to exit from this situation, it's necessary to retract a little the stabilizers, then switch the system OFF and ON.

ATTENTION

In low threshold mode, when trying to lift a load greater than the one for the intervention of the load limiter, the crane functions lock. If the crane does not have a winch, the only way out from this situation, is to lower the boom. This is allowed for half second every 10 seconds, in order to be able to put the load down.

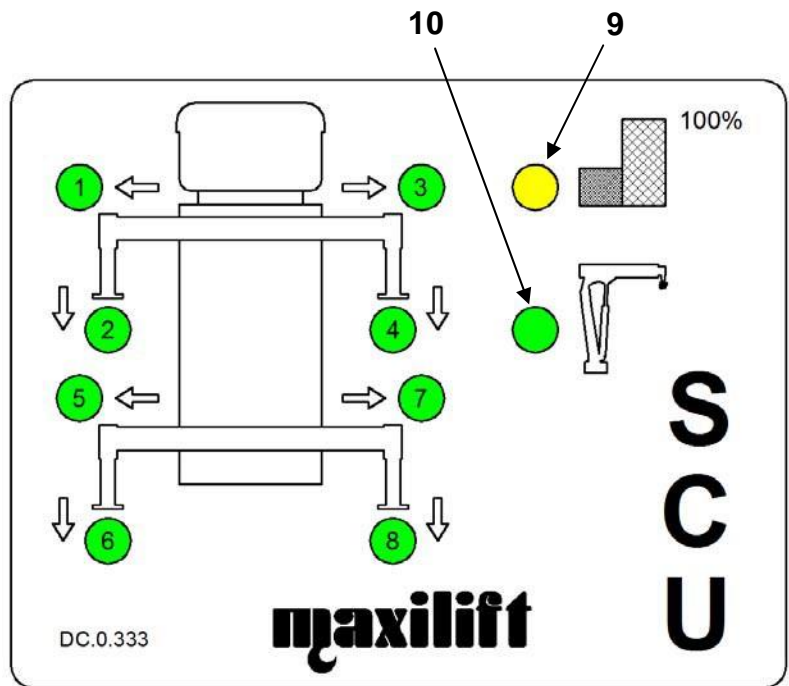

Pict. 16

8.2 Modification of the setting of the load limiter low threshold

The low threshold is factory set at a pressure value of 55 bar. This pressure value corresponds to a percentage of the load, at the maximum outreach of the last hydraulic extension, indicated on the load chart. This percentage is different, for every crane model, as indicated in the table. This is extremely important to take into account, when replacing the load limiter electronic card as well.

Crane model	Percentage
180.2	27%
180.3	25%
230.2	29%
230.3	28%
270.2	26%
270.3	23%
270L.2	25%
270L.3	21%
330.2	26%
330.3	25%
330.4	22%
380.2	27%
380.3	24%
380.4	22%
510L.2	24%
510L.3	19%
510L.4	17%

It is possible to modify the setting, as explained below.

8.2.1 Preparation for the setting

- 1) Prepare the load for the setting.
- 2) Remove the plastic protection from the control station.
- 3) Turn the load limiter OFF.
- 4) Open the load limiter box, removing the seals and the four screws.

8.2.2 Calibration procedure

- 1) Insert the bridge connector (placed inside the box, in a small nylon envelope) on jumper **J14**.
- 2) Switch the load limiter ON again by the key switch. The green LED **D3** will light up. Even if the red LED **D20** is lit up, go on with the procedure.
- 3) Push the button **SW1**; yellow LED **D21** will light up, while the red LED **D20** blinks. In this condition, the dump valve solenoid should be energized. Otherwise, it's necessary to activate its cartridge hydraulically, by screwing the manual override in.
- 4) Lift the load previously prepared, and bring it, with the boom in horizontal position, at the right distance.
- 5) Push the button **SW2**.
- 6) Push the button **SW1**, to exit from the calibration procedure; the yellow LED **D21** will light OFF. The red LED **D20** stays ON still, only if the system is in low threshold mode.
- 7) Retract the boom extension and check that the red LED **D20** lights OFF.
- 8) Turn the system OFF to store the setting.
- 9) Remove the bridge from jumper **J14**, and store it inside the box as found.

8.2.3 Checks

- 1) Switch the load limiter ON again, and wait until the self-test is finished.
- 2) Jib out and in the boom extensions a few times and check that the yellow and red lamps on the frontal panel light up according to the outreach.

8.2.4 Sealing the system

- 1) Close the box, and apply metal wire and seal on two screws of the cover, that is drilled for this purpose.
- 2) In case, restore the sealing of the manual operator of the dump solenoid valve, if it has been previously removed.

IMPORTANT 

Never switch the supply voltage OFF, during the calibration procedure, to avoid its failure.

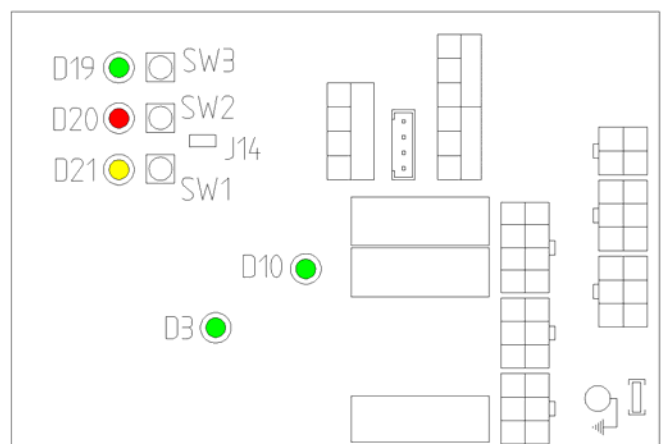

Pict. 17

8.3 SCU system components (Pict. 18)

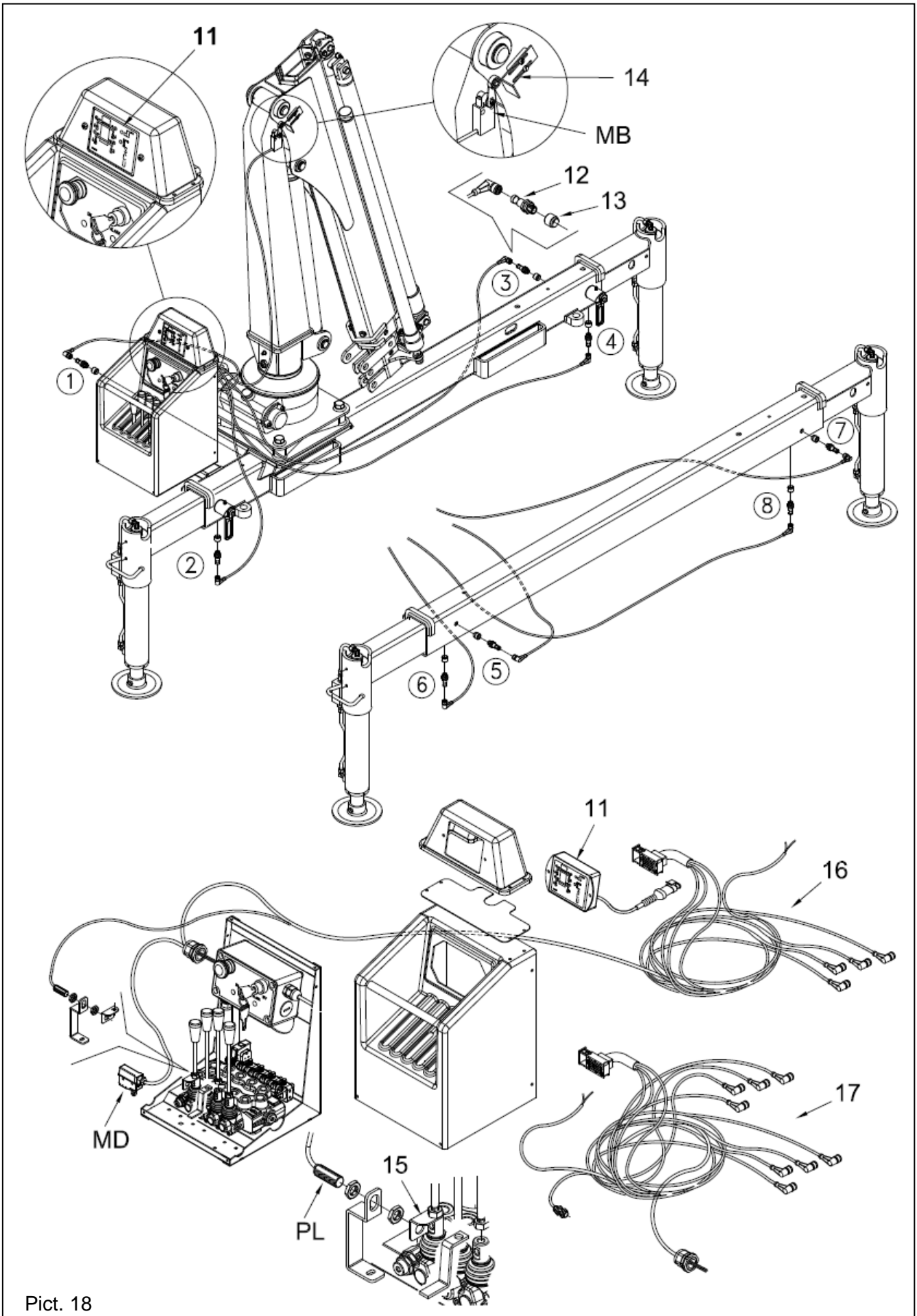

Pict. 18

8.3.1 SCU control unit (11)

It is placed on the control station. It contains the electronic card that, processes the signals coming from the stability sensors, and gives a visual signal on the front panel and interacts with the load limiter LME04 which it is connected to.

8.3.2 Stability sensors

These are PNP proximity switches (12) fixed to the main beam of the crane main stabilizer (and to the supplementary outrigger, if present).

Their purpose is to detect the complete extension of the extendable rods and the contact with the ground of the stabilizer plates.

All the stability sensors are NC connected.

8.3.2.1 Extension sensors

These are numbered: 1, 3, 5, 7 and horizontally positioned on the vertical plate of the main beam tube. Any of these sensors detect a hole on the extendable rod when completely extended. If this happens, the relevant LED on the panel is lit up, while those of the proximity itself are OFF, and a voltage signal is present on the white wire (or 2, if numbered) connected to the SCU input (Picts. 12-13). When the extendable rods are not completely extended, the LEDs on the proximities blink with the frequency of the square wave they are supplied with by the SCU electronic card.

8.3.2.2 Ground contact sensors

These are numbered: 2, 4, 6, 8 and vertically positioned underneath the tube of the main beam. Any of these sensors detect the extendable rod lifted from the lower side of the main beam. In this condition, the relevant LED on the panel is lit up, while those of the proximity itself are OFF, and a voltage signal is present on the white wire (or 2, if numbered) connected to the SCU input (Picts. 12-13). When the foot plates are not touching the ground, the LEDs on the proximities blink with the frequency of the square wave they are supplied with by the SCU electronic card.

NOTE:

Should it be necessary to position the sensors on the upper side of the main beam, this is possible (but not recommended), since the main beam is prefabricated, and the sensor has the proper wire, for this operating condition. It's necessary to cut the relevant signal wires (white or 2 if numbered) originally connected to the SCU inputs and connect it to the electronic card, to the black wires (or 4 if numbered) available (this way, they result NO connected). In this case, the signal is given when the extendable rod gets near to the upper side of the main beam. Further, the LEDs on the proximities blink when the foot plates touch the ground, therefore when detecting metal.

8.3.3 Boom stowage micro-switch MB

It is placed near the articulation between column and boom, and its lever is activated when the boom is folded.

The purpose of this micro-switch is:

- To enable the self-test on the stability sensors, when turning the system ON, in condition of boom completely folded.
- To lock all the functions, except for the one of the stabilizer, when a stability sensor activated is detected during the self-test.
- To bypass the self-test on the stability sensors, when the boom is in working position, and the system is switched ON after it has been switched OFF (with boom in working position and stabilizers set, the self-test would detect that the sensors are activated).
- To lock the stabilizer function, when the boom is in working position. This will avoid that the stabilizers previously set can be moved. This will ensure the boom is stowed completely, before closing the stabilizers, if they have been previously positioned.

If the stabilizer function was not locked, the following situation would be possible: once a full stabilization has been achieved with the boom in rest position, and subsequently, the boom has been brought in working position, the system is in high threshold mode. By retracting the stabilizers with the boom in working position, the system would go in to low threshold mode, but it would be possible to return to high threshold mode, by simply positioning the stabilizers,

although not completely (e.g. 2 extensions and 1 ground contact, with one outrigger; 4 extensions and 2 ground contacts, with two outriggers). The same would happen after having the system switched off and on. It would be possible never to fold the boom, so that the system would never perform the self-test on the sensors and the high threshold mode could be achieved without stabilizing the vehicle completely.

- To store the working condition before switching the system OFF, when the boom is in working position. This means that, if the system was working in the high threshold mode, even with one foot lifted, after having the system switched OFF (by the key switch or the emergency button), when switching the system ON again, the system still works in the high threshold mode. The micro-switch is NC (normally closed) connected. The contact is open when the boom is folded.

NOTE



The blue and brown wires on the other contact of This microswitch are available to supply the relay coil for the warning in the cabin that the crane is not stowed (Pict. 19).

The blue and brown wires are to be found along The cable of MB microswitch, where it is connected to the cable coming from the SCU, inside the sheath protecting the hoses.

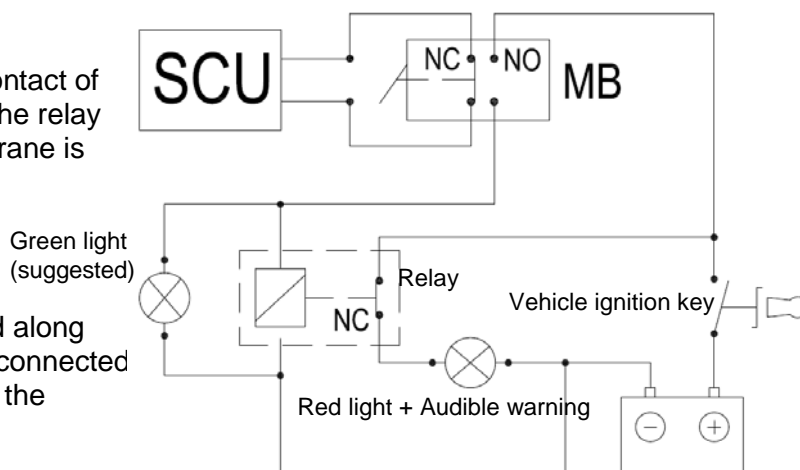

Pict. 19

8.3.4 Boom lowering micro-switch MD (connected to the load limiter) on the valve bank

It has two purposes:

- **To enable the boom lowering for half second every 10 seconds, in conditions of low threshold alarm.**

This allows, in low threshold mode, to put the load down, when trying to lift a load greater than the rated capacity. Otherwise, without this possibility, the only activation of the extension in function would not allow to put the load down, and, as a consequence, the load would remain always hung. Further, it allows the boom to fold completely, by little steps, if the system has gone in the low threshold alarm, whereas it was working in the high threshold before.

- **To allow boom lowering, in low threshold mode, otherwise it would continuously get locked.**

This is because a portion of the pressure in the piston side of the lifting cylinder, during the boom lowering function, is the one necessary to unlock the load holding valve.

Therefore, the activation of this micro-switch subtracts 47 bar of pressure (boom lowering correction parameter), to the pressure reading by the electronic card, during the boom lowering, in low threshold mode.

In the table below, are listed the pressure values necessary to open the load holding valve, during the boom lowering, without load applied to the crane. This pressure value (p_a) is different from a crane model to another. Further, the same crane model can have the standard valve (VA.1.033; pilot ratio 4,1:1) and the valve for the proportional remote control (VA.1.028; pilot ratio 3:1).

Crane model	p_a (VA.1.033) [bar]	p_a (VA.1.028) [bar]
180	35	48
230	37	50
270	41	55
330	36	48
380	38	51
510	36	50

8.3.5 Proximity on the stabilizer function lever PL

Every time the stabilizer lever is activated, the proximity detects that the lever is not in neutral position, and interacts accordingly with the status of the stowage micro-switch.

When the stabilizer lever is in neutral position, the LED on the display blinks with the frequency of the square wave it is supplied with by the SCU electronic card, detects a hole of a target **(15)** fixed on the stabilizer lever itself, giving a voltage signal on the black wire on input C7 of SCU (Picts. 12 – 13).

When the lever is activated, the proximity switch detects the metal around the hole of the target, the LED light goes OFF, and the signal on input C7 disappears.

8.3.6 Harness

Two harness versions are available:

- One for cranes with main stabilizer, without supplementary stabilizer, therefore for 4 stability sensors **(16)**
- One for cranes with main stabilizer and supplementary stabilizer, therefore for 8 stability sensors **(17)**

8.4 Diagnostic and Fault operating conditions

IMPORTANT

In order to carry out an effective diagnostic of the SCU-LME04 system, it's necessary to be aware of the information given at paragraphs: 1.2.2 - 2.1.4 - 6.1 - 6.4 - 6.5.

8.4.1 MB lever stuck in the position it has been with the boom folded

The micro-switch lever tends to get stuck in the position it has been when the boom is completely folded (stowed).

It's not possible to perform a self-test on it, since the two possible status of the contact are allowed in any of the operating conditions, and since this micro-switch is the one that manages the self-test on the stability sensors.

When the lever gets stuck (as sooner or later happens), this condition cannot be signalled by the warning in the cabin, because in that status, the warning is OFF. The following cases are possible:

- Once the stabilizers are completely set, as soon as a load is lifted, and at least one of the ground contact signals goes OFF, the systems goes in low threshold mode.
- When the boom is in working position, it detects the condition of boom folded. Therefore, it doesn't lock the stabilizer function. But, if the system is switched OFF and ON, if at least one of the stabilizer is set, the self-test locks all the crane functions except for the stabilizer.
- If the boom is not folded, it's possible to close the stabilizers and start driving without being warned that the boom is not folded, since the warning in the cabin is OFF (see NOTE at 8.3.3). Therefore, if the stabilizers are never set completely, they are always closed before driving, and the crane is never switched OFF before closing the stabilizers, the condition of this lever stuck is never detected. The only possibility to detect it is to check the LED 10 on the panel. When the boom is in working position, it never lights up.
- The system always performs the self-test when turning it ON. This ensures that the stability sensors functionality is always monitored.

8.5 Important information for replacing components

IMPORTANT

It is mandatory to indicate the crane serial number, in the following cases:

8.5.1 Replacing the load limiter main board

When replacing the load limiter main board, its high threshold and the low threshold values need to be calibrated, as explained in the paragraphs 4.2 and 8.2

ATTENTION

If the vehicle which the crane is installed onto is not stable with the standard setting of the low threshold, when the stabilizers are not positioned, it is necessary to re-calibrate and set the low threshold lower until the vehicle is stable (see 8.2).

8.5.2 Replacing the SCU control unit

The SCU control unit, in delivery conditions, is programmed to control a single outrigger, by means of 4 sensors.

If the vehicle is equipped with a supplementary outrigger, and therefore, to be monitored by 8 sensors, the SCU control unit needs to be properly programmed by changing one software parameter by means of a PC. In this case, when ordering the component, it's necessary to specify that it has to be delivered with the modified configuration.

