

Installation Guideline

The LoadLift must only be fitted to the vehicle by a competent person qualified to carry out the work.

The fitting must be formally certified by an authorised competent person in compliance with LOLER (Lifting Operations and Lifting Equipment Regulations 1998)

The lift is secured to the vehicle by a series of M12 bolts which must locate in a suitable sub structure constructed to suit the host vehicle.

Because of the variation in host vehicle design, the following instructions are supplied as a guide only, each installation being vehicle specific.

Electrical power for the power pack and control system is taken from the vehicle battery and allowance must be made to route the heavy power cable to the lift and also the control circuit cables to the isolator switch in a suitable position, usually on the vehicle dashboard.

Components for Typical Installation

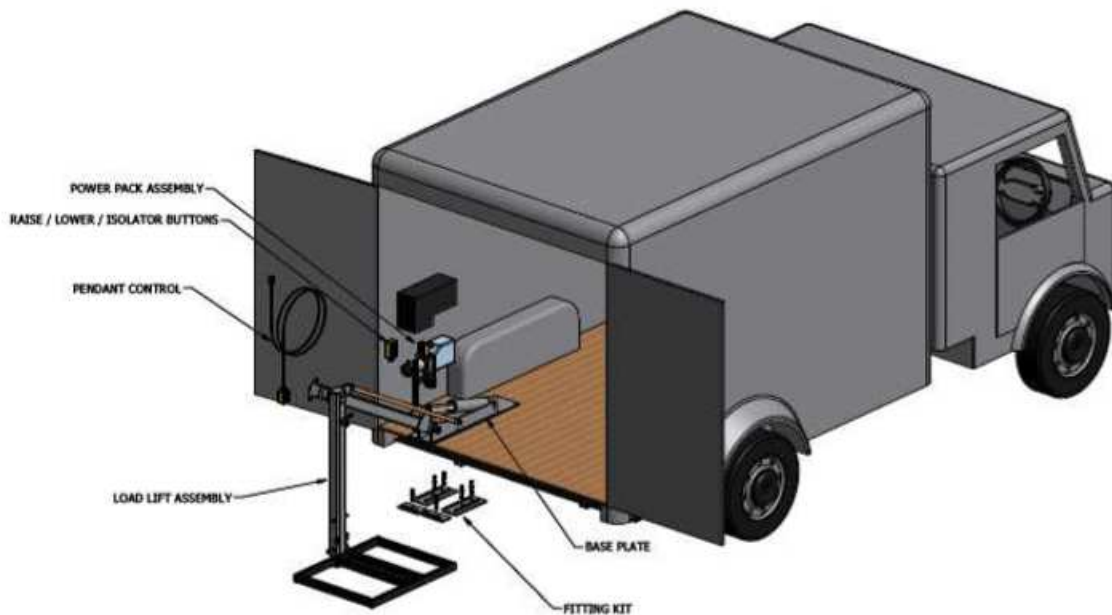

- 1) Prepare the work area to allow sufficient access around and underneath the vehicle.
- 2) Prepare the appropriate tools and materials.
- 3) Prepare signs, barriers, screens, fire extinguishers and any site specific requirements.
- 4) Position the vehicle, apply the brakes and make secure.
- 5) Unpack the LoadLift and check that there is no transit damage and that all components match the delivery note.
- 6) Prepare and disconnect the vehicle battery connections.
- 7) Prepare and remove the vehicle rear valance and set aside.
- 8) With the fixing brackets secured to the LoadLift use a fork lift truck or crane to offer the lift to the approximate position for mounting and note if any further items need to be removed or re positioned before proceeding.
- 9) Lower the LoadLift assembly and place away from the work area securely.
- 10) Remove the new fixing brackets from the LoadLift and secure them to the vehicle chassis using the nuts, bolts and washers supplied.
- 11) Offer up the LoadLift to the fixing brackets, realign and secure with the M12 fixing bolt assemblies supplied. Torque to 100Nm.
- 12) Subject to model and vehicle type, the power pack and control box may be fitted to the LoadLift as part of the assembly or may be supplied separately to position and secure in a suitable position on the vehicle.

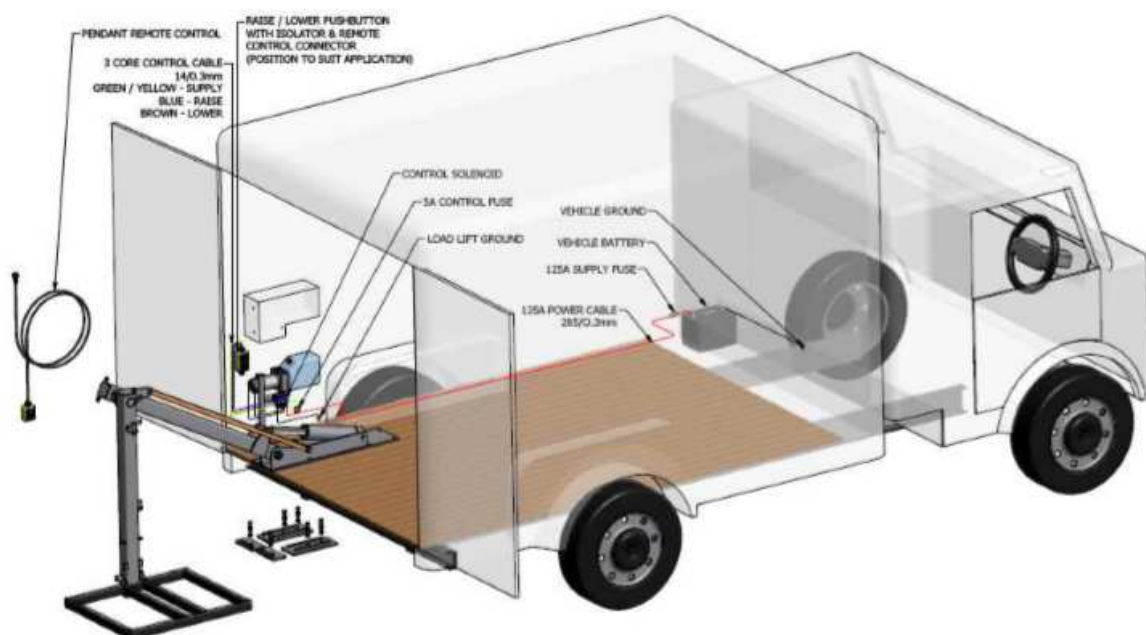

- 13) Position and secure the push button control in the operator position, usually adjacent to the lift on the upper body structure inside the rear door.
- 14) Route the 135A power cable from the vehicle battery compartment to the control box and secure in a safe position.
- 15) Prepare the connection of the power cable to the positive terminal of the battery. The 125A main fuse is supplied connected in line with a short length of 135A power cable. The other end of the 135A power cable is supplied connected to the solenoid in the control box.
- 16) Install the control circuit isolator switch, audible warning device and label on the dashboard in the vehicle cab or other convenient position.
- 17) Route the twin control cable (red & black cores) from the control box to the isolator switch in the vehicle cab and secure in a safe position.
- 18) Check and confirm that the 5A control circuit fuse is connected to the power supply terminal in the control box.
- 19) The black core of the twin control cable is supplied connected to the 5A fuse, making it the supply to the control circuit.
- 20) Prepare the other end of the black core of the twin control cable for connection to the incoming terminal of the isolator switch in the vehicle cab.
- 21) Prepare the connection of the red core of the twin control cable to the outgoing terminal on the isolator switch in the vehicle cab.
- 22) Make up a connection from the outgoing terminal of the isolator switch to the audible warning device and a connection from the audible warning device to a convenient ground connection.
- 23) The red core of the twin control cable is supplied connected to the green & yellow supply cable in the control box and then to the pushbutton control box.
- 24) Check and confirm that all the cable routing is protected from sharp corners and is effectively sealed at all entry / exit points.
- 25) Circuit test all the connections and cables for continuity and ground faults before re connecting the vehicle battery.
- 26) Check the oil level in the power pack and top up if necessary.
- 27) Before testing, briefly switch on the control circuit isolator to prove the audible warning.
- 28) Operate the LoadLift through one complete cycle to check the alignment. On some models, adjustment arms are fitted to ensure alignment to the floor and deck. If adjustment is required, lower the LoadLift so that it is just clear of the ground and isolate the circuit. Loosen the lock nuts and screw the adjusters to re align the platform. Secure the lock nuts on completion of the adjustment.

Electric Schematic

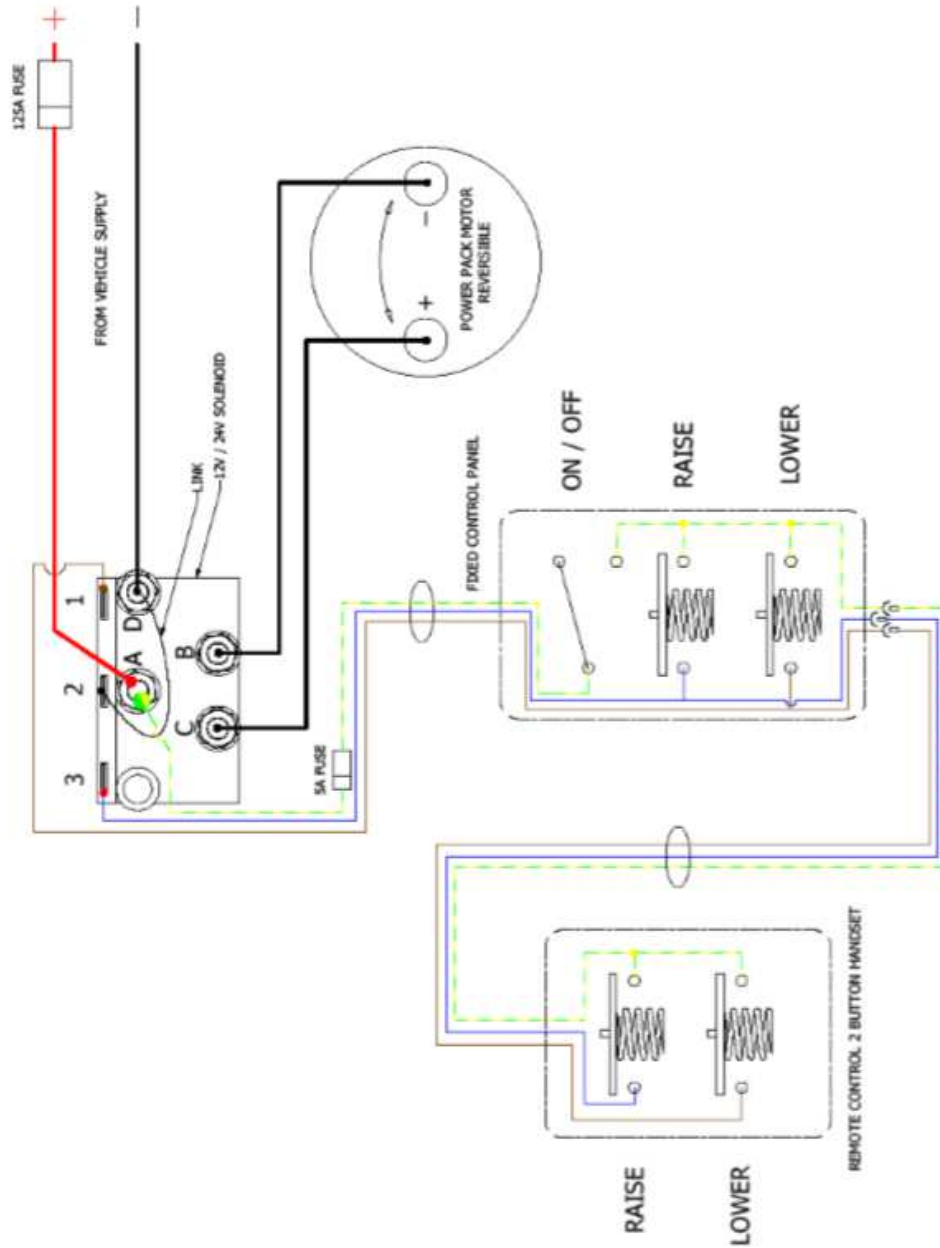

Hydraulic Schematic

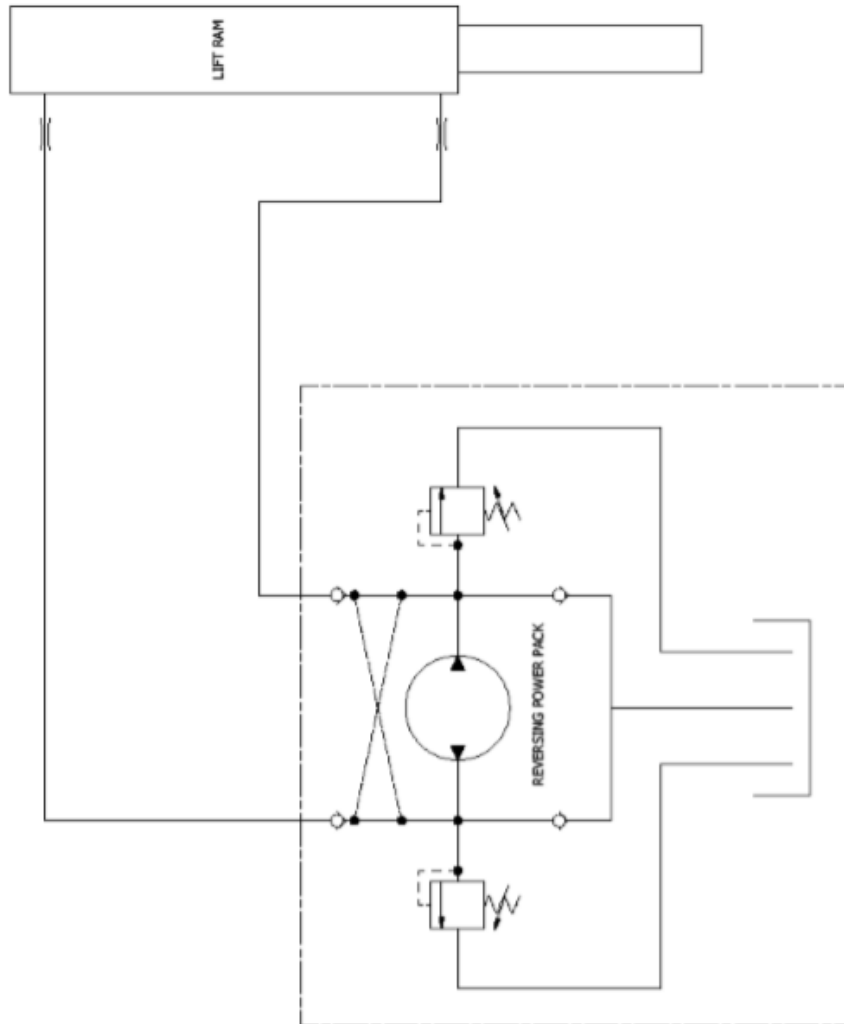

Testing

To comply with LOLER, the new mounting structure for the LoadLift has to be tested to 1.25 x MWL.

Formal documentation has to be completed by the competent person conducting the test to confirm there are no defects.

The LoadLift unit is tested and certified to this value before being released from the factory but should be included in the new test to confirm that the new mounting structure has not affected its integrity.

Procedure

To test the installation to 1.25 x MWL, the overload facility has to be increased to the test load.

- 1) Prepare the test area and cordon off the sweep area of the platform.
- 2) Unlatch the platform and manually lower it to the working position.
- 3) Ensure the working area is clear and switch on the isolator switch in the vehicle cab.
- 4) Ensure that the audible warning is working effectively.
- 5) Using the push button control, lower and raise the platform through one complete cycle observing and noting its operation and checking the oil level in the power pack.
- 6) Repeat the procedure several times to check the reaction of interface between the LoadLift, new mounting structure, vehicle body and vehicle chassis. An assistant should be employed to assist with the observation.
- 7) Isolate the control system in the vehicle cab and thoroughly inspect all joints and connections for signs of movement, deflection or deformation.
- 8) If all is satisfactory and acceptable and with the load lift platform in its lower loading position, place calibrated test weights to the value of 1.25 x MWL on the platform in a central position.
- 9) To lift the test weights, the operating pressure of the hydraulic system has to be increased to override the normal operating overload function. This is achieved by adjusting the relief valve on the power pack to increase the pressure.
- 10) First locate the pressure relief valve on the power pack and prepare the necessary tools for adjustment. Subject to model type, the relief valve is usually an allen key adjustment with lock nut, sited under a protective cap.
- 11) Switch on the isolator in the vehicle cab and prepare to re test as before.
- 12) Note the position of the relief valve adjuster and turn one quarter of a turn clockwise. Press the raise button. If the test load will not lift, repeat the procedure until the load will lift through its full

sweep. Avoid running the power pack too long whilst setting up for testing to avoid overheating the hydraulic oil and note down the number of turns made on the adjuster to achieve the test pressure.

13) Using the push button control, raise and lower the platform through one complete cycle observing and noting its operation.

14) Repeat the procedure several times to check the reaction of interface between the Loadlift, new mounting structure, vehicle body and vehicle chassis. An assistant should be employed to assist with the observation.

15) Isolate the control system in the vehicle cab and thoroughly inspect all joints and connections for signs of movement, deflection or deformation.

16) If all is satisfactory, remove the test load and replace it with a calibrated test load equal to the MWL. Reset the power pack relief valve adjusting screw back to its factory set position and re test. Fine adjustment of the relief valve may be necessary to enable the MWL to lift when the system is at operating temperature.

17) If all is satisfactory, remove the test loads and prepare the vehicle for operation noting that the deck and body side runners may have to be modified to fit around the new support structure. 18) Complete and submit the formal documentation to comply with the requirements of LOLER.