

PH110.2

TECHNICAL DATA	PH110.2
Lifting capacity	10kNm
Max. lifting height from crane base	3400mm
Max. working slope	5°
Max. working pressure	200bar
Suggested oil flow	4-6l per min.
Electro-hydraulic power unit supply voltage	12V/24V
Max. absorption electro-hydraulic power unit (12V)	160A
Max. absorption electro-hydraulic power unit (24V)	75A
Hydraulic oil tank capacity (H version)	15l
Hydraulic oil tank capacity (electric version)	5l

CRANE WEIGHTS	kg
PH110.2	125-145
Base weight with quick fitting kit & 1 mechanical stabiliser	40
Base weight with 2 extendable stabilisers	64-88

DIMENSIONS

CRANE	A	B1	B2
PH 110.2	1210	665	780

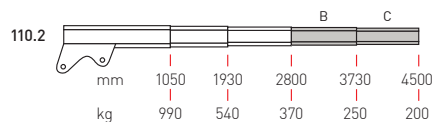
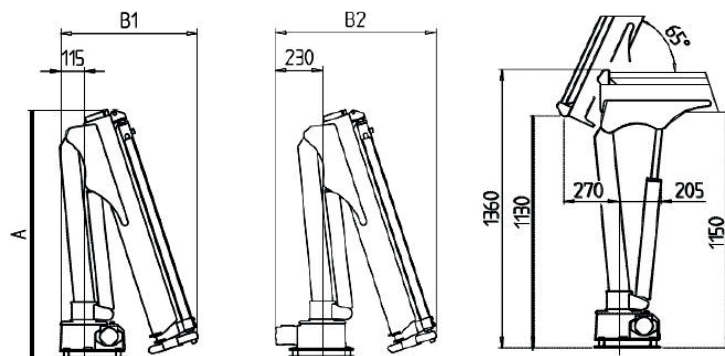

Hydraulic extension
 Standard manual extension
 B/C/D Optional manual extension
 * "D" version



Penny Hydraulics
VEHICLE MOUNTED EQUIPMENT

Penny Hydraulics Limited

Station Road | Clowne | Chesterfield | Derbyshire | S43 4AB | United Kingdom
 t +44 (0) 1246 811475 | f +44 (0) 1246 810403

w www.pennyhydraulics.com | e sales@pennyhydraulics.com