

PH400L.2

TECHNICAL DATA	PH400L.2
Lifting capacity	42kNm
Max. lifting height from crane base	5600mm
Max. working slope	15°
Max. working pressure	230bar
Suggested oil flow	15-18l per min.
Hydraulic oil tank capacity	30l

CRANE WEIGHTS	kg
PH400L.2	490

CRANE	DIMENSIONS				
	A	B	C	D	E
PH 400L.2	1800	1450	280	410	1610

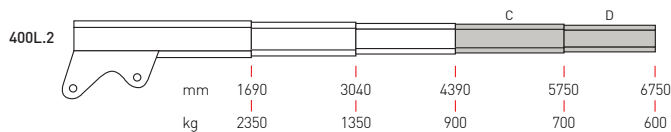
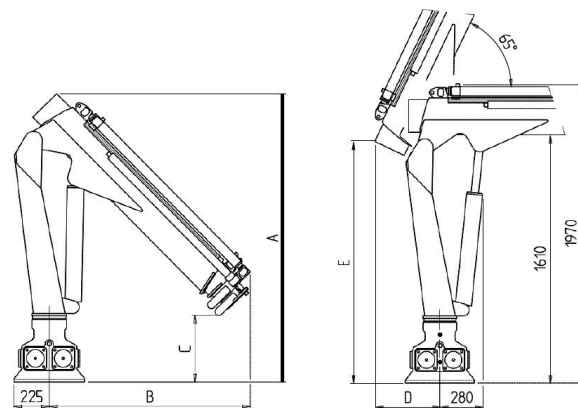

Hydraulic extension
 Standard manual extension
 Optional manual extension
 * "D" version



Penny Hydraulics Limited

Station Road | Clowne | Chesterfield | Derbyshire | S43 4AB | United Kingdom
 t +44 (0) 1246 811475 | f +44 (0) 1246 810403

w www.pennyhydraulics.com | e sales@pennyhydraulics.com