

OPERATING & MAINTENANCE MANUAL

VME – SwingLift Cranes – KJ Range

PH_VME_OM_005 Rev 1



Contents

Safety Information	4
Introduction	6
Range Overview	7
SwingLift KJ250/1.....	7
<i>Dimensional Drawing</i>	7
SwingLift KJ250/1.5.....	8
<i>Dimensional Drawing</i>	8
SwingLift KJ250/2.....	9
<i>Dimensional Drawing</i>	9
SwingLift KJ250/2 RPT.....	10
<i>Dimensional Drawing</i>	10
Method of Operation	11
Prior to Operation.....	11
Operation.....	11
Transportation	12
Fault Finding	13
Maintenance	14
Planned Maintenance Schedule	15
Interval.....	15
Daily / Before Use	15
Weekly	15
3 Monthly.....	15
6 Monthly.....	15
12 Monthly.....	15
Load Test Procedure	16
Method	16
Overload Test.....	16
Thorough Examination	17
BS7121 Part 2.....	17
Lorry Loader Servicing	18
Penny Hydraulics Limited Warranty Policy	19
UK Mainland.....	19
Other Locations.....	19
Technical Data	20

Power Supply	20
Electrical Specification	20
Typical Weights	20
Safe Working Load	20
Noise Levels	20
COSHH - Terminal Disposal	20
Typical Wiring Layout.....	21
EC Declaration of Conformity	22
Spare Parts List	23
KJ250/1 – Exploded View	23
KJ250/1 – Parts List	24
KJ250/1.5 – Exploded View	26
KJ250/1.5 – Parts List	27
KJ250/2 – Exploded View	28
KJ250/2 – Parts List	29
KJ250/2 RPT – Exploded View	30
KJ250/2 RPT – Parts List	31
Training Register	32
Work Record.....	33
Penny Hydraulics Ltd Standard Terms and Conditions (for the Supply of Goods and Services to non-consumers).....	34
1 Interpretation.....	34
2 Basis of Contract	34
3 Goods	35
4 Delivery	35
5 Quality.....	36
6 Title and Risk	37
7 Price and Payment	38
8 Customer’s Insolvency or Incapacity	39
9 Limitation of Liability.....	40
10 Force Majeure.....	40
11 General.....	40

Safety Information

For optimum safety and to keep your Penny Hydraulics SwingLift in good working order, follow these simple Dos and Don'ts.



Do not exceed the Maximum Working Load

Your Penny Hydraulics lifting equipment is clearly marked with the MWL (Maximum Working Load).



Do not drag or tow

To avoid damage to the SwingLift and mounting points, it must be used only for lifting.



Do not expose the red section of rope

This section is marked to alert the user that they are approaching the full extent of the rope and should not proceed further.



Do not wrap the rope around the load

This will cause excessive chafing and splintering of the rope. Appropriate lifting accessories should be used instead.



Rope must not spool from top of winch

If your wire rope is spooling from the top of your winch, the rope is wound incorrectly on the drum. The SwingLift **must not** be used until this is rectified.



Do not leave a load suspended

Never leave a load suspended or unattended.



Always use the rope hook to stow the crane

The rope hook is one of several methods used to secure the crane for transit.



If supplied, always use the stabiliser leg

Not every Penny Hydraulics SwingLift is supplied with a support leg but when this is supplied, it **must** be used.



Always stow the crane before driving

To avoid damage to the SwingLift, vehicle and surroundings, the crane **must** be stowed correctly before driving.

- In the interest of safety, all personnel involved in the operation of the crane must read and understand this manual. If they do not then they must not operate the equipment.
- Do not use the KJ250 if it is not supported by valid documentation recording a Thorough Examination being carried out by a Competent Person within the last 12 months.
- The KJ250 must not be used for man riding.

- The KJ250 should be inspected every six months and serviced annually by a competent person. See “Maintenance” in this manual for full Statutory responsibilities.
- The KJ250 must not be overloaded. Refer to the safe working load signs attached to the equipment.
- The KJ250 must only be operated by trained and competent personnel. Training is offered by Penny Hydraulics and a training register is included at the back of this manual.
- Use only correct and certified lifting attachments. Lifting attachments must be formally certified by Thorough Examination every 6 months.
- Use only genuine parts and accessories.
- During operation of the KJ250, access to the area should be restricted to those personnel essential to the operation only.
- Do not leave any load suspended between lifting / lowering operations.
- All safety notices must be adhered to at all times.
- Keep the KJ250 properly maintained by a competent person. See the “Maintenance” section in this manual.
- Do not adjust or interfere with any factory settings.
- Isolate, immobilize and lock-off the equipment before commencing any maintenance routine.
- Ensure any site-specific barriers, guards and fencing are securely in place before commencing any work.
- Do not modify or re-install this machine without seeking guidance from Penny Hydraulics Ltd.
- Do not allow any person beneath a suspended or moving load.
- Never interfere with the unit. It should run smoothly at all times, if in doubt call the HELPLINE telephone number 01246 811475.

Introduction

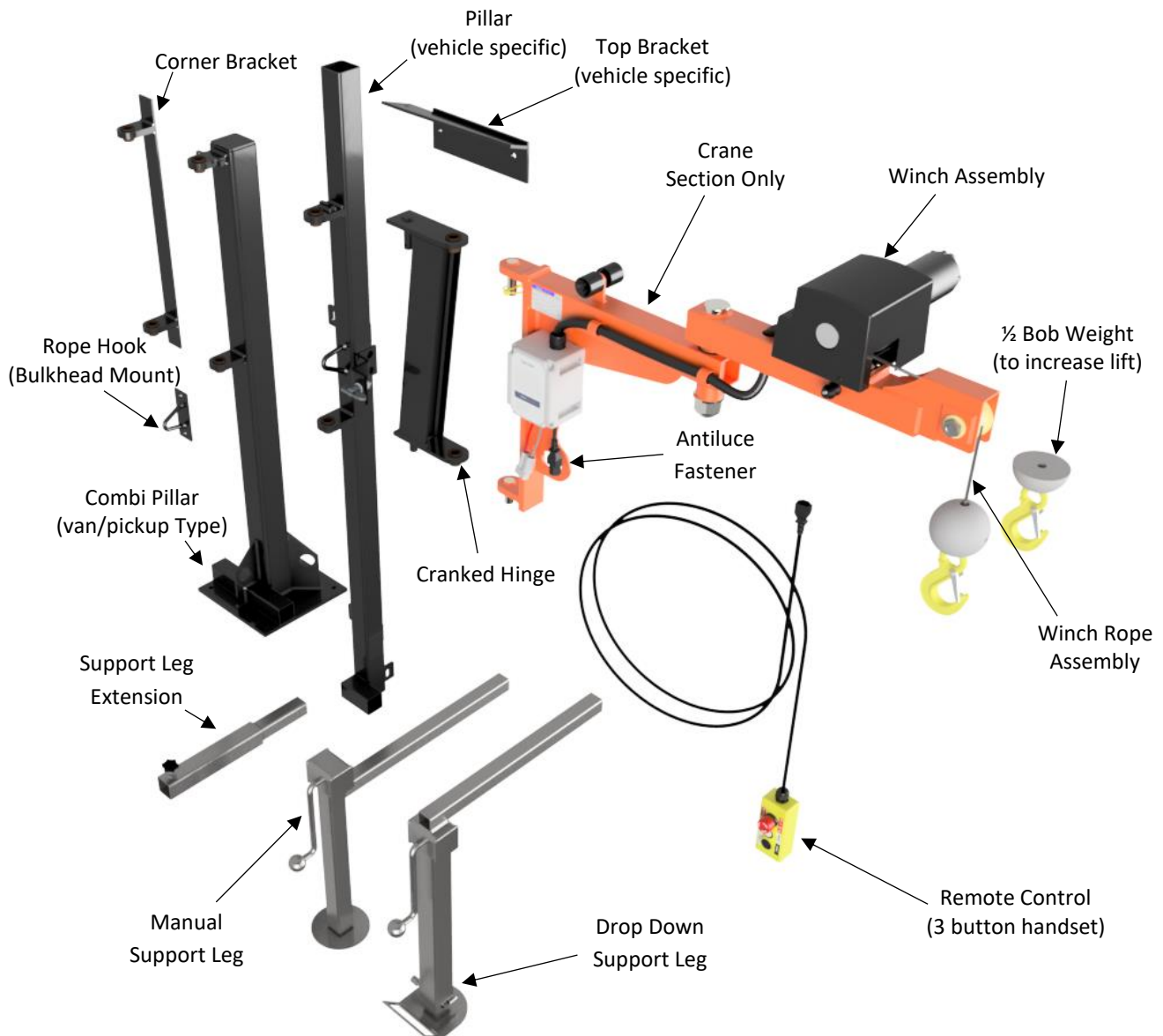

Thank you for purchasing a Penny Hydraulics SwingLift Knuckle Joint crane.

The SwingLift KJ250 is a vehicle mounted crane designed and manufactured at our factory in Chesterfield, UK to safely lift and position loads of up to 250kg.

The crane is operated remotely from a handheld pendant control with all functions being protected by inbuilt overload features, powered by the vehicle battery.

These operating instructions tell you what you need to know about its operation along with guidance on safety and general care. Please study them carefully.

Due to our company's policy of continuous improvement, the following descriptions and illustrations used in this manual and parts book are without prejudice. We reserve the right to make alterations in order to increase the performance of our product, or for any other reason. We are not obliged to alter these instructions accordingly.

Range Overview

The KJ range of cranes consists of four basic models:

SwingLift KJ250/1

250KG maximum capacity knuckle joint crane with a 1m boom allowing lifts within a 2m arc. Most commonly van or headboard mounted.

Dimensional Drawing

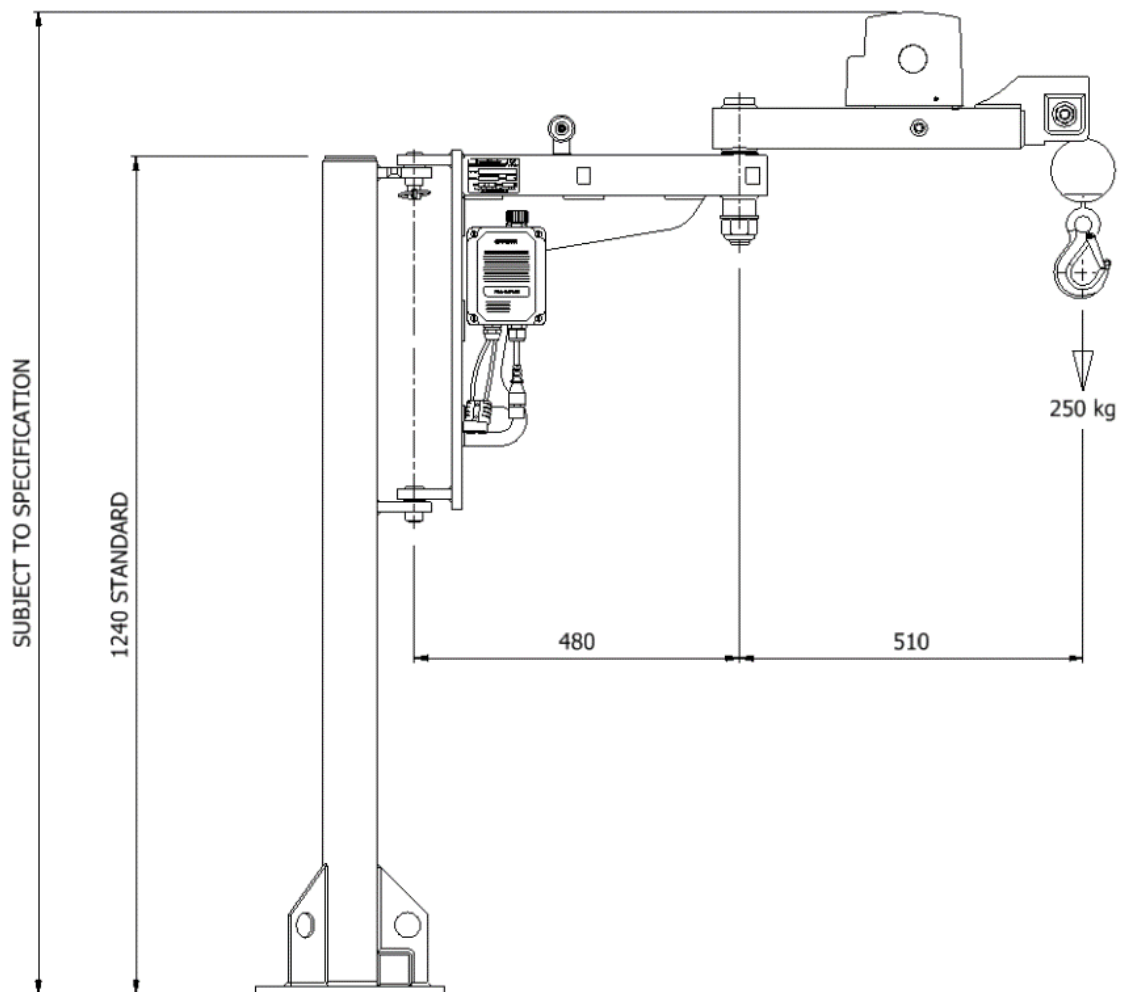

SwingLift KJ250/1.5

250KG maximum capacity knuckle joint crane with a 1.5m boom allowing lifts within a 3m arc. Most commonly van or headboard mounted.

Dimensional Drawing

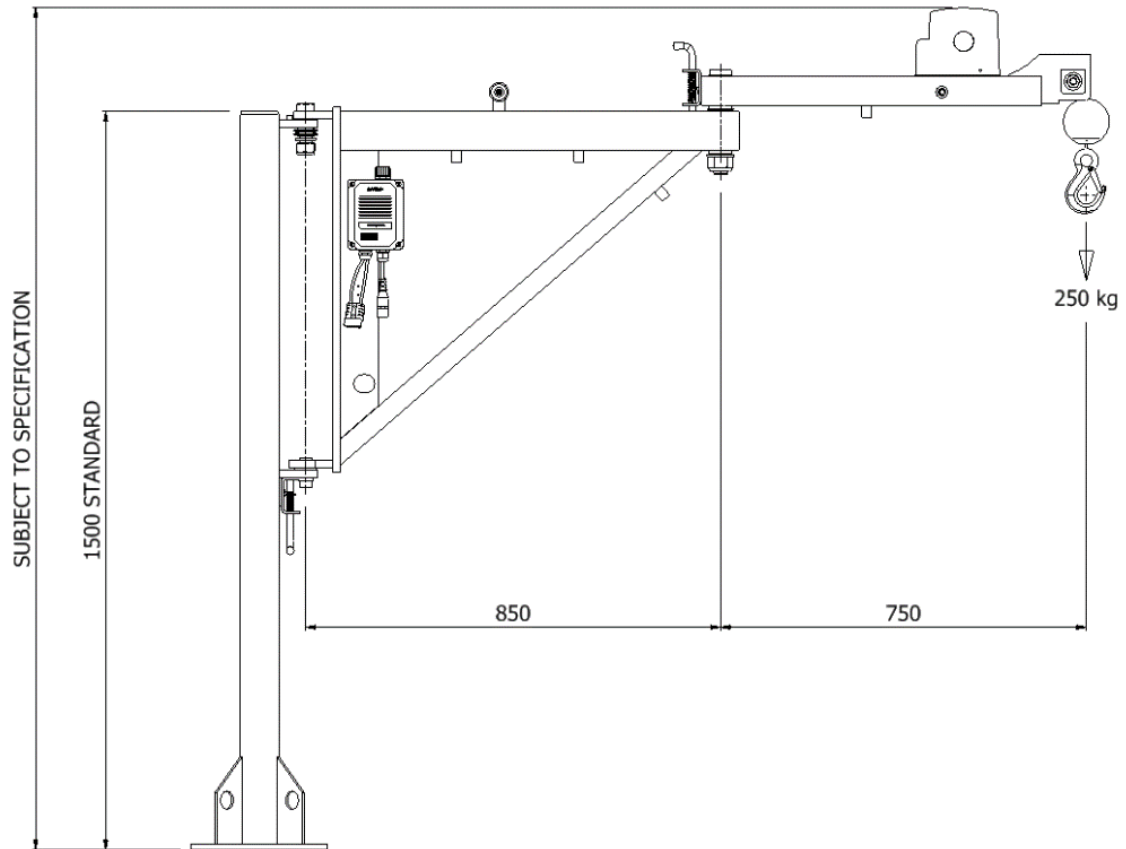

SwingLift KJ250/2

250KG maximum capacity knuckle joint crane with a 2m boom allowing lifts within a 4m arc. Pick-up, combi-pillar or headboard mounted.

Dimensional Drawing

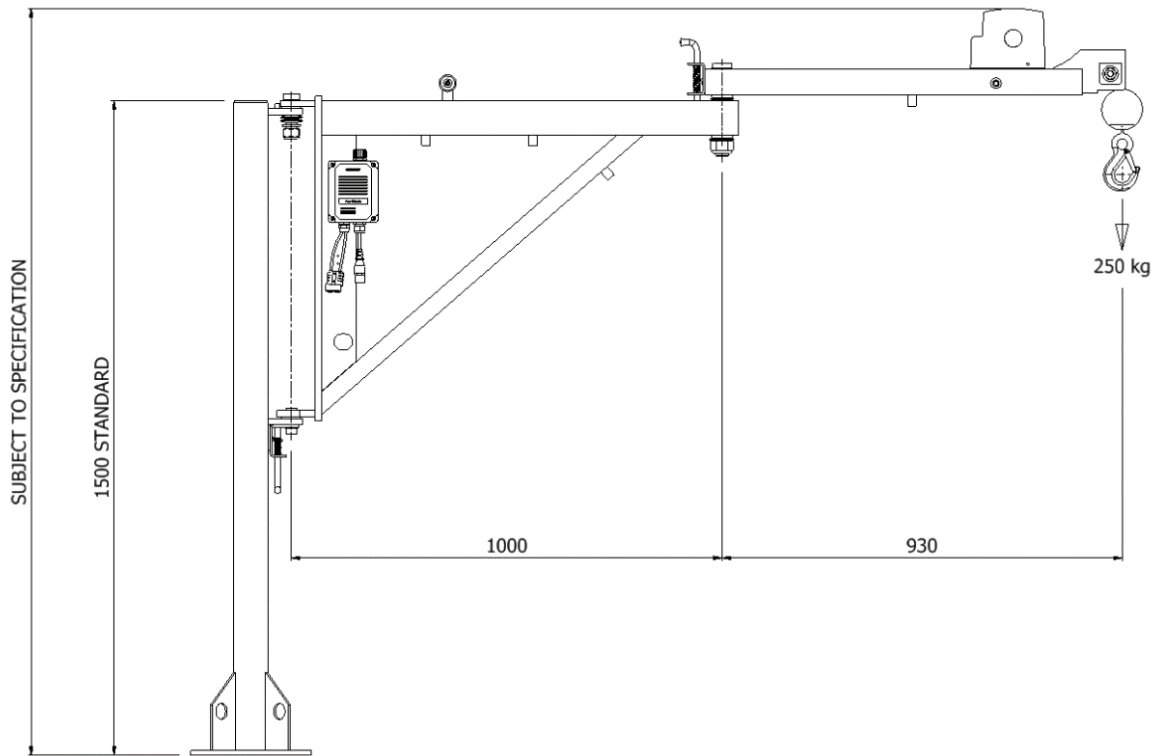

SwingLift KJ250/2 RPT

250KG maximum capacity knuckle joint crane with a 2m boom allowing lifts within a 4m arc and 350° slew.

Dimensional Drawing

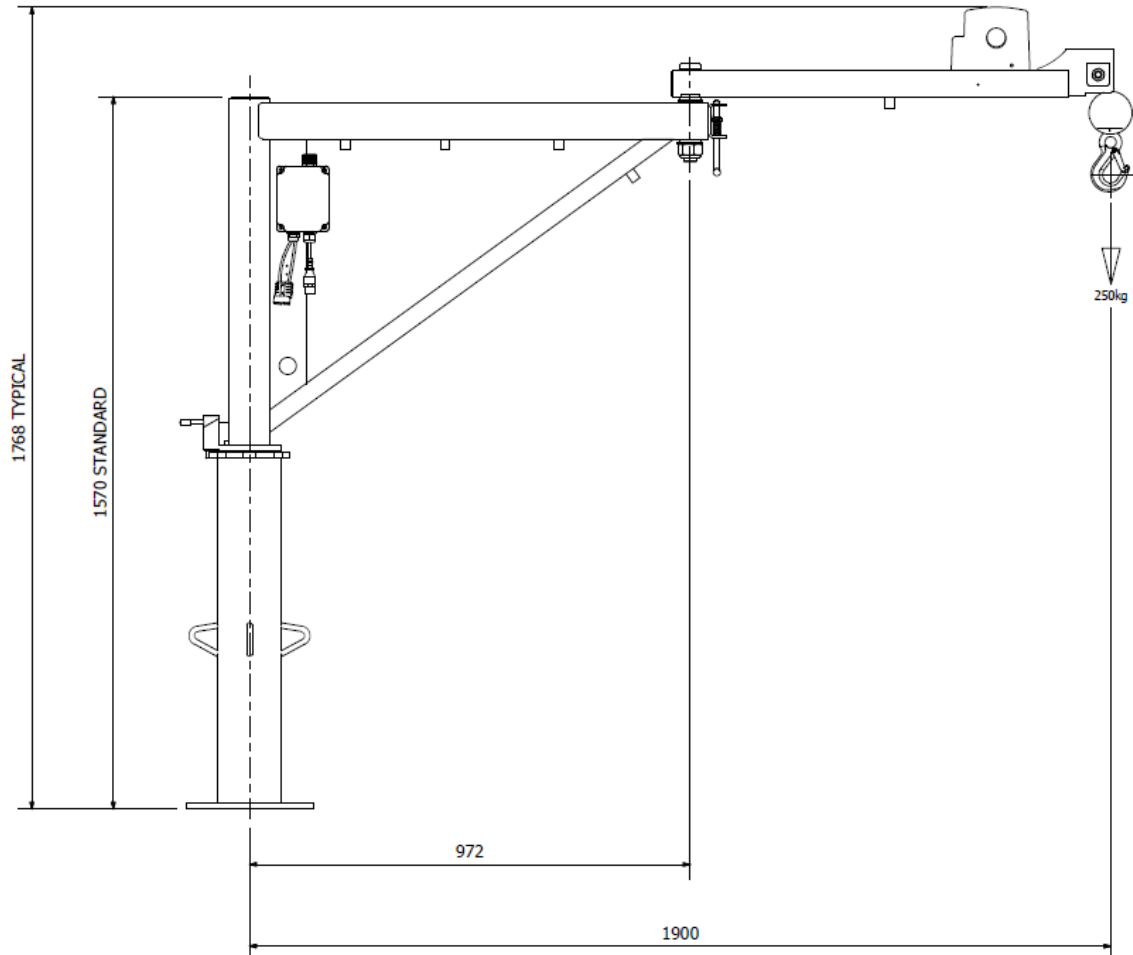

Method of Operation

Prior to Operation

1. Read the Operating and Maintenance manual and ensure all persons involved in the lift are trained and competent to do so.
2. Check and ensure that the necessary documentation for the KJ250 and Lifting attachments is valid and up to date. Ensure that the Report of Thorough Examination does not exceed 12 months for the crane and 6 months for the associated lifting accessories.
3. Ensure you have a risk assessment for the lift to be undertaken.
4. Employ any PPE equipment required or stipulated by your employer or risk assessment.
5. Ensure the crane installation is inspected prior to use for defects (see Planned Maintenance Schedule).
6. Ensure the vehicle is on firm and level ground with the handbrake applied and wheel chocks deployed where necessary.
7. Before operating check for potential hazards such as: overhead electric wires, nearby structures, public roads or paths, railways or rivers. Also pay attention to any underground services; eg gas, electric, drainage etc. Employ barriers or safety guarding required and identified by the risk assessment.
8. Extend the support legs and adjust to ground level using a suitable spreader pad if necessary.
9. Check the power connector from the vehicle is firmly in place.
10. Plug in the pendant control to the control box on the side of the boom support.
11. Using the pendant control button, lower the rope and release it from the rope retaining eye.
12. Release the boom retaining latch and all the locking pins and manually position the rope over the load.
13. The crane is now ready for use.

Operation

1. The pendant control functions are clearly marked on the hold to run buttons and can now be used as required.
2. Ensure the pendant e-stop is disengaged.
3. Check that the load to be lifting is within the capacity of the crane.
4. Position the load hook directly above the load. The crane should be used for vertical lifting only. No dragging of the load. No man riding.
5. Lower the lifting hook and attach using suitably certified lifting attachments only.
6. Carefully lift the load and manoeuvre to the required position. Do not steer the load by pulling or pushing on the wire rope.
7. Keep clear of the suspended load as far as practically possible and do not try to physically restrain it if the balance suddenly changes. Never stand beneath the suspended or moving load.
8. Do not leave the suspended or attached load unattended.
9. Do not to drive the vehicle with a suspended load or drive with the support legs in the down position.
10. On completion of the operation, ensure the KJ250 is folded into the transport position with the rope attached to the retaining eye and all the locking devices firmly secured.
11. Ensure that the support leg is withdrawn and secured.
12. Detach the pendant control and store securely.

Transportation

Ensure all latches and methods of stowage are fully secured and the winch rope is tensioned before moving the vehicle.

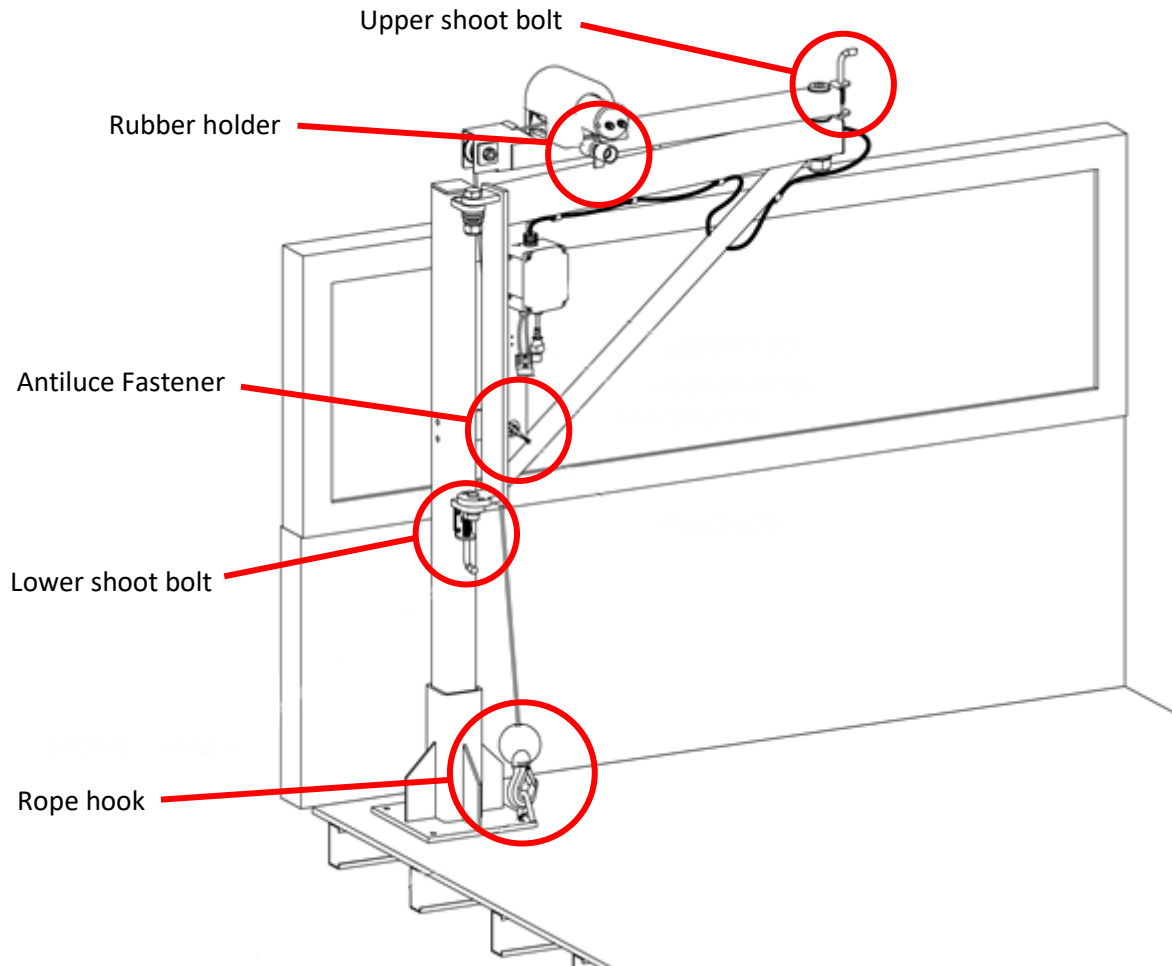

Fault Finding

Fault	Cause	Remedy
No response when operating Raise / Lower buttons	No power from the battery	Check supply fuse and replace if necessary. Check all cable connections are clean and sound
	Faulty earth connection	Check, clean and secure all earth points
	Faulty or discharged vehicle battery	Recharge or replace the battery
Crane will not lift but will lower	Crane overloaded	Lower off and remove the excessive load
	Rope bunched on pulley or winch.	Ensure that rope is free to travel
Crane will not swivel freely	Clutch mechanism seized.	Loosen, clean and reset spring washers

Maintenance

Your SwingLift KJ250 series vehicle mounted crane is subject to the Lifting Operations and Lifting Equipment Regulations 1998 (LOLER) which is a statutory requirement to record on a formal document, the safe working condition of the crane, attachments and mounting structure.

Penny Hydraulics Ltd Service Team offers a service package to meet customer requirements and conform to LOLER certification. Please see Service Contract form enclosed.

The following Planned Maintenance Schedule is designed to monitor the safe working order of the KJ250 and includes a Thorough Examination by a Competent Person required by LOLER.

LOLER also requires that a Thorough Examination is carried out following any exceptional circumstance that may affect the safety of the equipment.

Any defects found whilst carrying out the Planned Maintenance Schedule must be reported and recorded and the equipment is taken out of operation until action by a Competent Person is undertaken.

The Planned Maintenance Schedule may require the use of parts and consumables.

Planned Maintenance Schedule

Before any work is undertaken, ensure the site supervisor is informed and that all safety precautions are observed and adhered to.

Pay attention to site-specific safety and PPE requirements.

Unless dynamic checks, tests or setting up procedures are being carried out, always isolate the machine from the power supply.

Where dynamic checks are being performed, it is recommended that an assistant is designated to be on call if required.

Ensure a clean working area and sufficient cleaning materials.

Ensure the work area is cordoned off, paying particular attention to the sweep areas required for dynamic testing.

On receipt of a new machine and before it is put into service, check that there is no transit damage or evidence of mishandling.

Interval	Maintenance Task
Daily / Before Use	Check visually for signs of external damage.
	Check all guards are securely in place.
	Check for loose or missing nuts, bolts and fasteners.
	Check the hoist rope for kinks, broken strands and corrosion.
	Check the lifting hook and connection to the rope.
	Check for damage to electrical cables and connectors
Weekly	Check all as for Daily.
	Thoroughly clean the support structure and check the security of the interface with the vehicle.
3 Monthly	Check all as for Daily, Weekly.
	Remove the rope assembly from the winch and check the full length for kinks, broken strands and corrosion. Replace if necessary.
	In severe operating conditions, remove the pin and rope pulley and check for excessive wear. Replace if necessary.
	Refit the pulley and rope assembly ensuring smooth lapping on the winch drum.
6 Monthly	Check all as for Daily, Weekly, Monthly and 3 Monthly.
	Thoroughly examine the main structures and subframes for soundness and signs of deflection.
	Thoroughly inspect all welds.
	Thoroughly check the security of all fixings on the main body and subframes.
	Thoroughly examine all pivot points for excessive play. Remove the pivot pins and thoroughly inspect the condition of the pins and bushes and replace where necessary.
	Thoroughly examine all electrical components, cables and connectors.
12 Monthly	Check all as for Daily, Weekly, 3 Monthly and 6 Monthly.
	Carry out a full load test as set out in the Load Test Procedure.
	Carry out a statutory thorough examination as required by LOLER.

Load Test Procedure

A load test must be carried out periodically to assess the integrity of the KJ250 and its supporting structures.

Any defects or signs of potential failure must be rectified before the machine is allowed back into service.

Method

1. Prepare the vehicle for operation in a safe working area, with the support leg firmly set and cordon off the area with appropriate barriers and work in progress signs.
2. Prepare the maximum prescribed test weights as determined by the KJ250 model number.
3. Clear the site, admit power, connect the pendant control and rotate the KJ250 in line with the axis of the chassis and the boom outboard.
4. Without load, manoeuvre the crane through all extents to ensure correct operation.
5. Lower the rope and attach the hook to the test weight prescribed.
6. Raise the load clear of the ground.
7. Check for signs of excessive flexing, structural deformation, paint flaking and excessive play in the joints.
8. Rotate the KJ250 through its maximum swing and repeat the checks.
9. Return the weight to its starting position and detach.

On completion of the tests, restore the vehicle to its normal driving position, restore the working area and complete the necessary documentation.

Overload Test

An overload test is carried out on all new KJ250s at the factory and forms part of the test certificate requirements.

If the KJ250 is fitted to the vehicle by Penny Hydraulics Ltd or one of its authorized dealers, the system including the substructure and vehicle interface will be Overload Tested as part of the test procedure.

An Overload Test must be carried out if:

- The KJ250 is fitted to a new vehicle or modified structure.
- Any Modifications have been carried out to the KJ250 or support structure.
- Following any incident which may have caused damage to the KJ250 or its supporting structure.

To carry out an Overload Test, elements of the system protection features must be overridden and therefore must only be carried out by a competent person.

In severe or extreme conditions, it is recommended that an Overload Test is incorporated into the Annual Load Test of KJ250 and its supporting structure

Please contact Penny Hydraulics Ltd for further information.

Thorough Examination

The Lifting Operations and Lifting Equipment Regulations (LOLER) replaced the legal requirement for the four-yearly Overload Test with the annual Thorough Examination and Inspection, and made it the responsibility of the Competent Person to determine if and when an Overload Test should be carried out, on the grounds that "the design of certain lifting equipment is such that damage may be caused by conventional Overload Tests". Loader cranes do not fall into this category, as witnessed by the fact that BS7121 Part 2 has an entire section devoted to the testing of loader cranes. Load Testing is a requirement of ALLMI and BS7121 Parts 2 and 4.

Inspection of the lorry loader by a competent person to determine if it is safe for continued use until the next thorough examination is due. Thorough Examinations should be conducted at least every 12 months. A thorough examination will also be required:

- If the lorry loader is involved in an accident or dangerous occurrence.
- After a significant change in conditions of use.
- After long periods out of use.
- At shorter intervals as determined by the Competent Person.

Please note that in addition to the above, lifting equipment for lifting persons or an accessory for lifting, must be thoroughly examined at least every six months.

BS7121 Part 2

Occasion	Minimum test and thorough examination
Before being first taken into service	Full test including 25% overload
Annually after being first put into service	Proof load test of rated capacity +10% at full radius and through the full slewing arc, and a Thorough Examination
4 years after first being put into service	Full test including 25% overload
8 years after first being put into service	Non-destructive test of the structure
After each structural repair or component change	Full test including 25% overload
When chassis is changed	Full test including 25% overload
Is removed and refitted	Full test including 25% overload

Lorry Loader Servicing

Penny Hydraulics Limited manufactures a range of Swinglift Cranes, Taillift, Steplift, Loadlift and Tyre Press products, which are supported by a fleet of dedicated service vans fully stocked with original equipment spares and manned by trained engineers.

Current legislation requires that each item of lifting equipment must be thoroughly examined at least once in every period of twelve months by a competent person. Additionally, the lifting equipment must be inspected at suitable intervals between thorough examinations. Our service contract will ensure continued safe, reliable use of the equipment and full compliance with current legislation.

The operator is required to carry out regular inspections and report any faults found.

The standard contract provides for an annual service and an interim six-monthly inspection or for total peace of mind we offer a Fully Comprehensive option. In all cases, a test certificate will be issued with a copy being left on site and a further copy sent together with our invoice. We will also keep a copy for our records that can be forwarded to enforcing authorities on your behalf as necessary.

Our database of all equipment ensures that statutory inspections are kept up to date and can help customers with many items of equipment to predict forthcoming servicing budgets.

A Help Line telephone number is provided with each service contract for the operators to seek assistance directly from our Service Department. There is no call out or labour charge for help required in-between scheduled visits and any parts used will be charged on the next invoice.

Should this be of interest then in the first instance please contact the Service Department on 01246 810403.

Penny Hydraulics Limited Warranty Policy

This Policy is intended to provide our customers with the best possible support to ensure trouble-free use of their new Penny Hydraulics lifting equipment.

Products sold by the Company are guaranteed to be free from defective material and workmanship for a period of one year from the date of invoice or from the date of the commissioning certificate.

This warranty applies only under the following conditions:

- The unit or part must not have been subject to neglect or abuse or operated under abnormal conditions or in an unapproved application.
- The responsibility of the Company is restricted to what is, in their judgement an adequate repair or replacement of the Company's product.
- An authorised engineer must carry out a six-monthly inspection.
- The warranty is void if examination reveals that the unit or part has been repaired or adjusted other than by an authorised engineer.
- Normal service repairs carried out by authorised engineers are supported by their own warranty.
- Warranty does not extend to consumable items requiring replacement due to normal wear and tear.

Any claim under warranty must be made in the first instance by contacting Penny Hydraulics Ltd Service Department on 01246 811475 or via email at service@pennyhydraulics.com. The decision will then be made on how best to proceed after consultation with the customer.

UK Mainland

We will normally have one of our own engineers based around the country visit the site to rectify the problem. This policy may be varied at our discretion, but it is our aim to give the very best possible response to minimize product downtime and inconvenience.

Other Locations

Warranty is limited to a parts only service but in certain areas, we have service partners who may be able to assist. Any defective item should be returned to Penny Hydraulics Ltd for inspection and any valid warranty claim will include reasonable carriage costs both ways. A replacement part will then be sent to the customer.

No variation of the warranty as stated in the Company's Standard Terms and Conditions of Sale is authorised unless agreed in writing by a Director of the Company. This is the only warranty given and the Company accepts no other responsibility.

Technical Data

Power Supply

Standard **SwingLift** KJ250s require a 12volt (24V Optional) DC electrical supply. This should be terminated in a 50A SB plug. Any circuit breakers employed in the system must be of a type that can cope with the surge of the electric motor.

Electrical Specification

12 volts DC 40A
24 volt optional
240 volt – contact Penny Hydraulics Ltd.

Typical Weights

Standard **SwingLift** KJ250 70kg subject to specification including winch unit.

Safe Working Load

Each **SwingLift** KJ250 is marked individually with its Maximum Working Load.

Noise Levels

A survey sheet giving full details is available on request. Briefly, the results are as follows: -

Winch running 65dB(A)

These levels are well below those at which hearing can be damaged and below levels at which action is required under the noise at work regulations.

COSHH - Terminal Disposal

Penny Hydraulics will remove and dispose of the entire crane in an environmentally sound manner when required.

Typical Wiring Layout

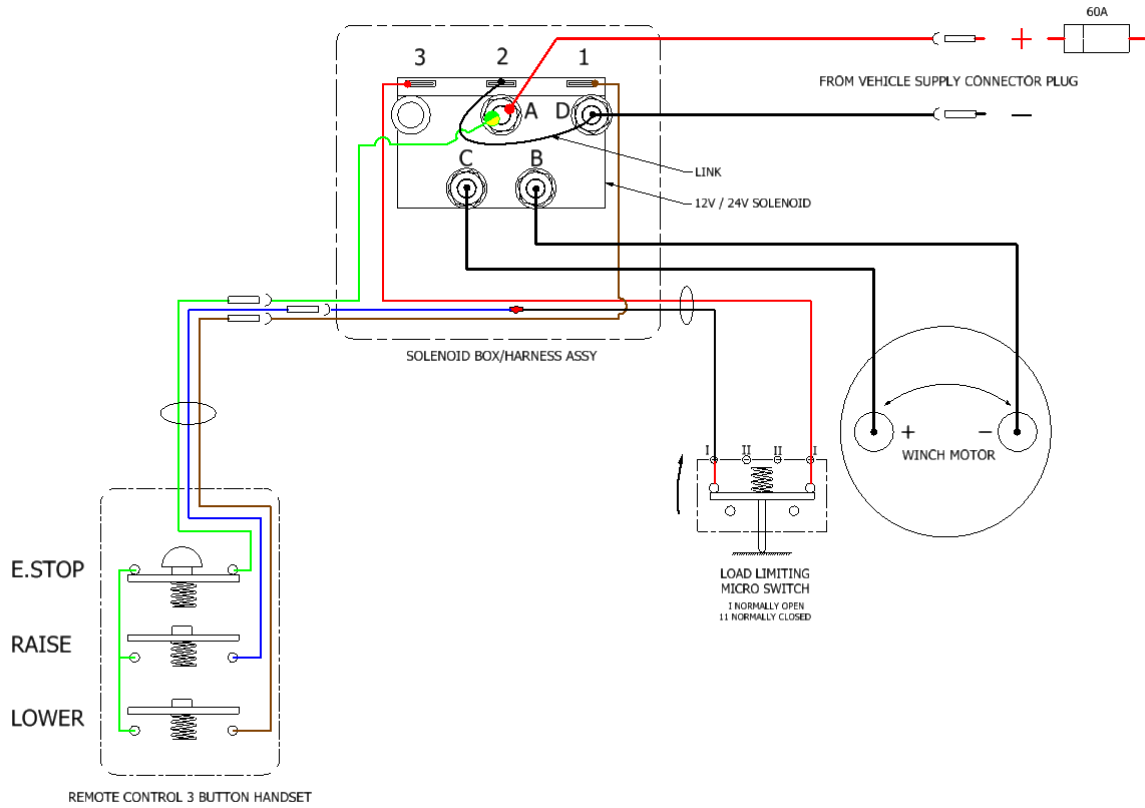

EC Declaration of Conformity

This declaration relates exclusively to the machinery in the state in which it was supplied, and excludes components, which are added, and/or operations carried out subsequently by the final user.

We Penny Hydraulics Limited, Station Road Industrial Estate, Station Road, Clowne, S43 4AB.

Hereby declare that the product(s) listed below: -

Model:	SwingLift Knuckle Joint Series
Serial No:	

Conforms to the essential requirements of 2008 / 1597, The Supply of Machinery (Safety) Regulations 2008 and the following Directives, Standards and other Normative Documents where appropriate.

EU Directives and Regulations	Machinery Directive 2006/42/EC Electrical Equipment (Safety) Regulations 1994 European Council EMC Directive 89/336/EEC
Standard(s)	BS 7121 Parts 1,2 and 4 BS EN 982 Safety of Machinery EN 50081-1: 1997; Electromagnetic Compatibility, General Standard Radiated RF Emissions Class B (30MHz – 300MHz)
Normative Documents	DIN 15018 Steel Structures BS 2573 Rules for design The Lifting Operations and Lifting Equipment Regulations 1998. The Provision and Use of Work Equipment Regulations 1998.
All information is given within a Technical File compiled by: Mr. Terry Brocklehurst c/o Penny Hydraulics Ltd.	

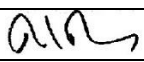
Place: Penny Hydraulics Limited	Signature: 
Date:	Full Name: R G Penny
	Position: M.D.

BS EN ISO 9001: 2015 British Standards Institute Registered Company
 Certificate No. FM 20203

Spare Parts List

KJ250/1 – Exploded View

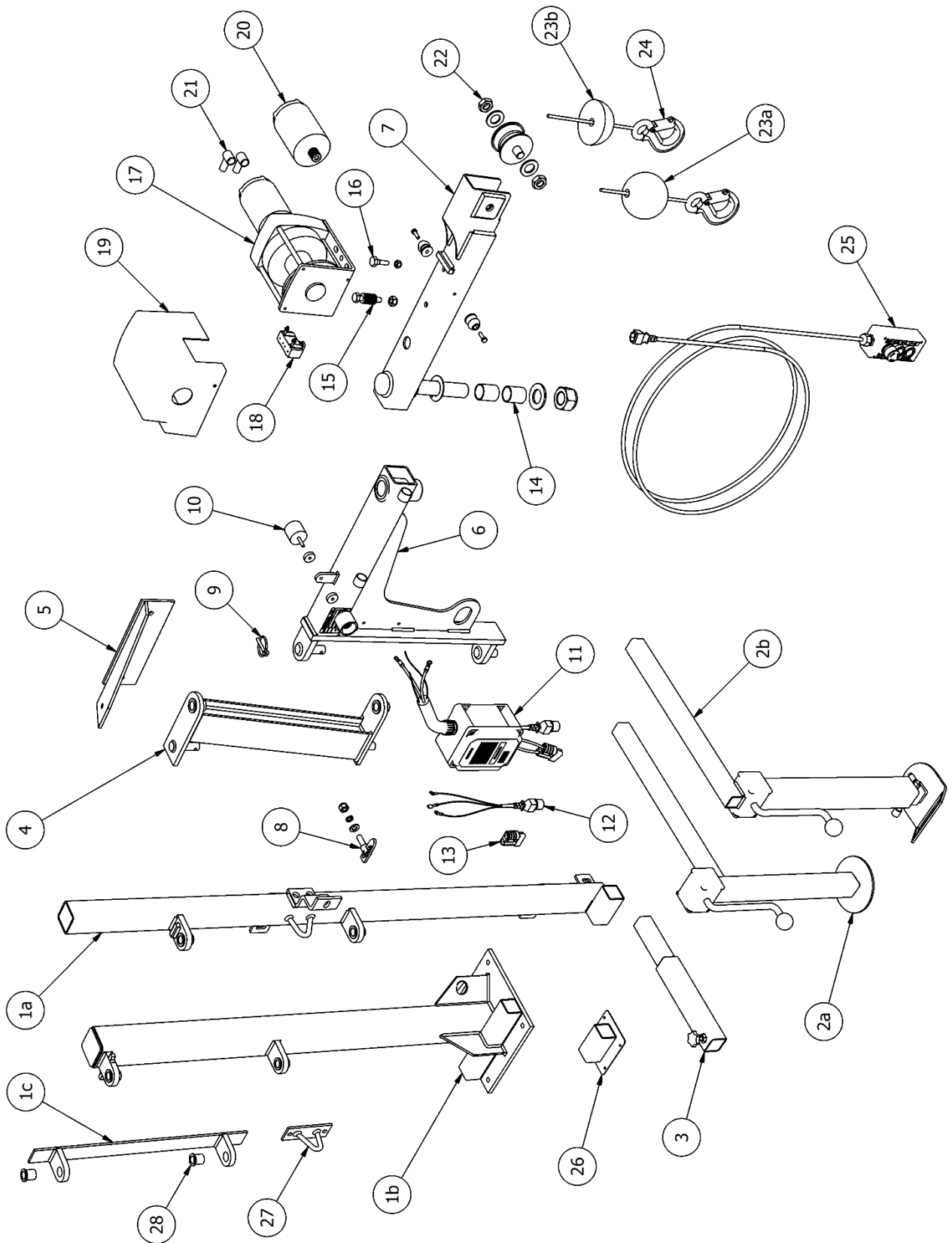

KJ250/1 – Parts List

ITEM	PART NUMBER	DESCRIPTION	QTY	
1	a	Subject to Specification	Van Pillar - Assembly	1
	b	541-000124	Combi Pillar - Assembly	1
	c	011-000441	Corner Bracket - Assembly	1
2	a	190-000006	Support Leg (2 Tier) - Assembly	1
	b	190-000015	Support Leg (3 Tier) - Assembly	1
3		503-000078	Leg Extension - Assembly	1
4		158-000029	Cranked Hinge - Assembly	1
5		Subject to Specification	Van Top Mounting Bracket - Assembly	1
6		056-000314	Crane Body	1
7		056-000313	2nd Boom	1
8		064-000001	Antiluce Fastener - Assembly	1
9		539-000043	Lynch Pin	1
10		173-000006	Rubber Holder (Male & Female) - Assembly	1
11	a	195-000040	Solenoid Box & Wiring Harness - 12V	1
	b	195-000041	Solenoid Box & Wiring Harness - 24V	1
12		547-000033	Remote Connector & Tail	1
13		108-000001	Anderson Power Connector - 50A	1
14		035-000056	Joint Bearing - Assembly	1
15		713-200005	Disc Spring - Assembly	1
16		200-000009	Shoulder Bolt - Assembly	1
17	a	077-000024	Winch Assembly - 12V - Left Hand (LH)	1
	b	077-000023	Winch Assembly - 12V - Right Hand (RH)	1
	c	077-000026	Winch Assembly - 24V - Left Hand (LH)	1
	d	077-000025	Winch Assembly - 24V - Right Hand (RH)	1
18		692-000008	Microswitch - Assembly	1
19	a	123-000035	Winch Cover - L/H	1
	b	123-000036	Winch Cover - R/H	1
20	a	614-000005	Winch Motor - 12V	1
	b	614-000007	Winch Motor - 24V	1
21		042-000001	Terminal Rubber Boot	2
22		555-000017	Pulley Wheel - Assembly	1
23	a	022-000002	Bob Weight - Assembly	1
	b	022-000004	Half Bob Weight - Assembly	1
24	a	079-000008	Rope 15' (4.5m) & Hook - Assembly	1
	b	079-000009	Rope 20' (6.0m) & Hook - Assembly	1
	c	079-000010	Rope 30' (9.1m) & Hook - Assembly	1
25		560-000016	Remote Control (3 Button Handset)	1
26		Subject to Specification	Support Leg Stowage Bracket - Assembly	1
27		079-000050	Rope Hook (Bulkhead Mounted) - Assembly	1
28		035-000049	Flanged Bush	2

ITEM	PART NUMBER	DESCRIPTION	QTY	
1	a	Subject to Specification	Van Pillar - Assembly	1
	b	541-000124	Combi Pillar - Assembly	1
	c	011-000441	Corner Bracket - Assembly	1
2	a	190-000006	Support Leg (2 Tier) - Assembly	1
	b	190-000015	Support Leg (3 Tier) - Assembly	1
3		503-000078	Leg Extension - Assembly	1
4		158-000029	Cranked Hinge - Assembly	1
5		Subject to Specification	Van Top Mounting Bracket - Assembly	1
6		056-000314	Crane Body	1
7		056-000313	2nd Boom	1
8		064-000001	Antiluce Fastener - Assembly	1
9		539-000043	Lynch Pin	1
10		173-000006	Rubber Holder (Male & Female) - Assembly	1
11	a	195-000040	Solenoid Box & Wiring Harness - 12V	1
	b	195-000041	Solenoid Box & Wiring Harness - 24V	1
12		035-000056	Joint Bearing - Assembly	1
13		713-200005	Disc Spring - Assembly	1
14		200-000009	Shoulder Bolt - Assembly	1
15	a	077-000024	Winch Assembly - 12V - Left Hand (LH)	1
	b	077-000023	Winch Assembly - 12V - Right Hand (RH)	1
	c	077-000026	Winch Assembly - 24V - Left Hand (LH)	1
	d	077-000025	Winch Assembly - 24V - Right Hand (RH)	1
16		692-000008	Microswitch - Assembly	1
17	a	123-000035	Winch Cover - L/H	1
	b	123-000036	Winch Cover - R/H	1
18		042-000001	Terminal Rubber Boot	2
19		555-000017	Pulley Wheel - Assembly	1
20	a	022-000002	Bob Weight - Assembly	1
	b	022-000004	Half Bob Weight - Assembly	1
21	a	079-000008	Rope 15' (4.5m) & Hook - Assembly	1
	b	079-000009	Rope 20' (6.0m) & Hook - Assembly	1
	c	079-000010	Rope 30' (9.1m) & Hook - Assembly	1
22		560-000016	Remote Control (3 Button Handset)	1
23		Subject to Specification	Support Leg Stowage Bracket - Assembly	1
24		035-000049	Flanged Bush	2

KJ250/1.5 – Exploded View

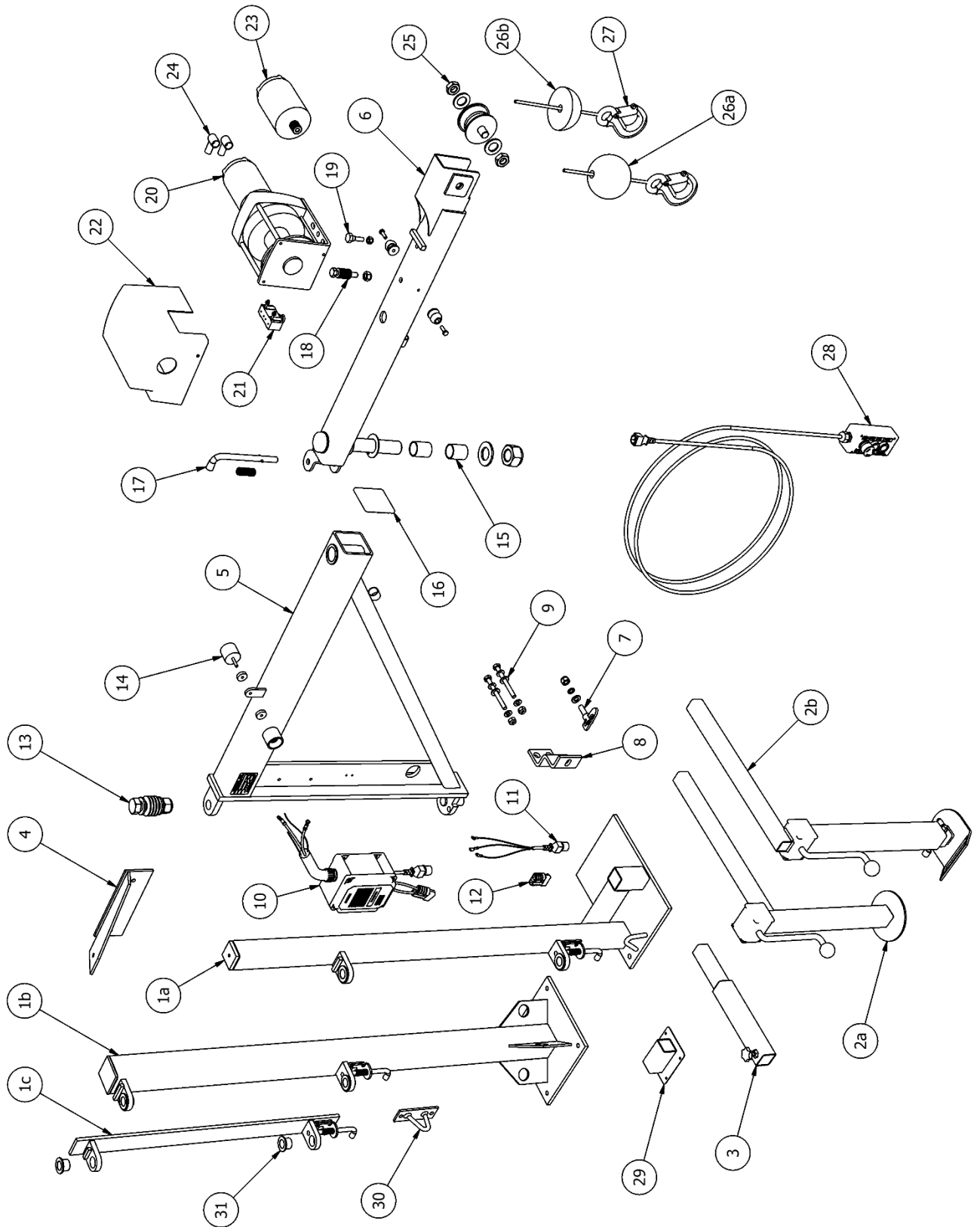

KJ250/1.5 – Parts List

ITEM	PART NUMBER	DESCRIPTION	QTY	
1	a	Subject to Specification	Van Pillar - Assembly	1
	b	541-000012	Combi Pillar - Assembly	1
	c	011-000346	Corner Bracket - Assembly	1
2	a	190-000006	Support Leg (2 Tier) - Assembly	1
	b	190-000015	Support Leg (3 Tier) - Assembly	1
3		503-000078	Leg Extension - Assembly	1
4		Subject to Specification	Top Mounting Bracket - Assembly	1
5		056-000318	Crane Body	1
6		056-000319	2nd Boom	1
7		064-000001	Antiluce Fastener - Assembly	1
8		011-000129	Antiluce Bracket	1
9		206-000001	Antiluce Fitting Kit	1
10	a	195-000010	Solenoid Box & Wiring Harness - 12V	1
	b	195-000011	Solenoid Box & Wiring Harness - 24V	1
11		547-000033	Remote Connector & Tail	1
12		108-000001	Anderson Power Connector - 50A	1
13		713-200008	Anti-slew Tensioner - Assembly	1
14		173-000006	Rubber Holder (Male & Female) - Assembly	1
15		035-000056	Joint Bearing - Assembly	1
16		547-000018	End Cap	1
17		079-000025	Shoot Bolt - Assembly	1
18		713-200005	Disc Spring - Assembly	1
19		200-000009	Shoulder Bolt - Assembly	1
20	a	077-000024	Winch Assembly - 12V - Left Hand (LH)	1
	b	077-000023	Winch Assembly - 12V - Right Hand (RH)	1
	c	077-000026	Winch Assembly - 24V - Left Hand (LH)	1
	d	077-000025	Winch Assembly - 24V - Right Hand (RH)	1
21		692-000008	Microswitch - Assembly	1
22	a	123-000035	Winch Cover - L/H	1
	b	123-000036	Winch Cover - R/H	1
23	a	614-000005	Winch Motor - 12V	1
	b	614-000007	Winch Motor - 24V	1
24		042-000001	Terminal Rubber Boot	2
25		555-000017	Pulley Wheel - Assembly	1
26	a	022-000002	Bob Weight - Assembly	1
	b	022-000004	Half Bob Weight - Assembly	1
27	a	079-000008	Rope 15' (4.5m) & Hook - Assembly	1
	b	079-000009	Rope 20' (6.0m) & Hook - Assembly	1
	c	079-000010	Rope 30' (9.1m) & Hook - Assembly	1
28		560-000016	Remote Control (3 Button Handset)	1
29		Subject to Specification	Support Leg Stowage Bracket - Assembly	1
30		079-000050	Rope Hook (Bulkhead Mounted) - Assembly	1
31		039-000002	Flanged Bush	2

KJ250/2 – Exploded View

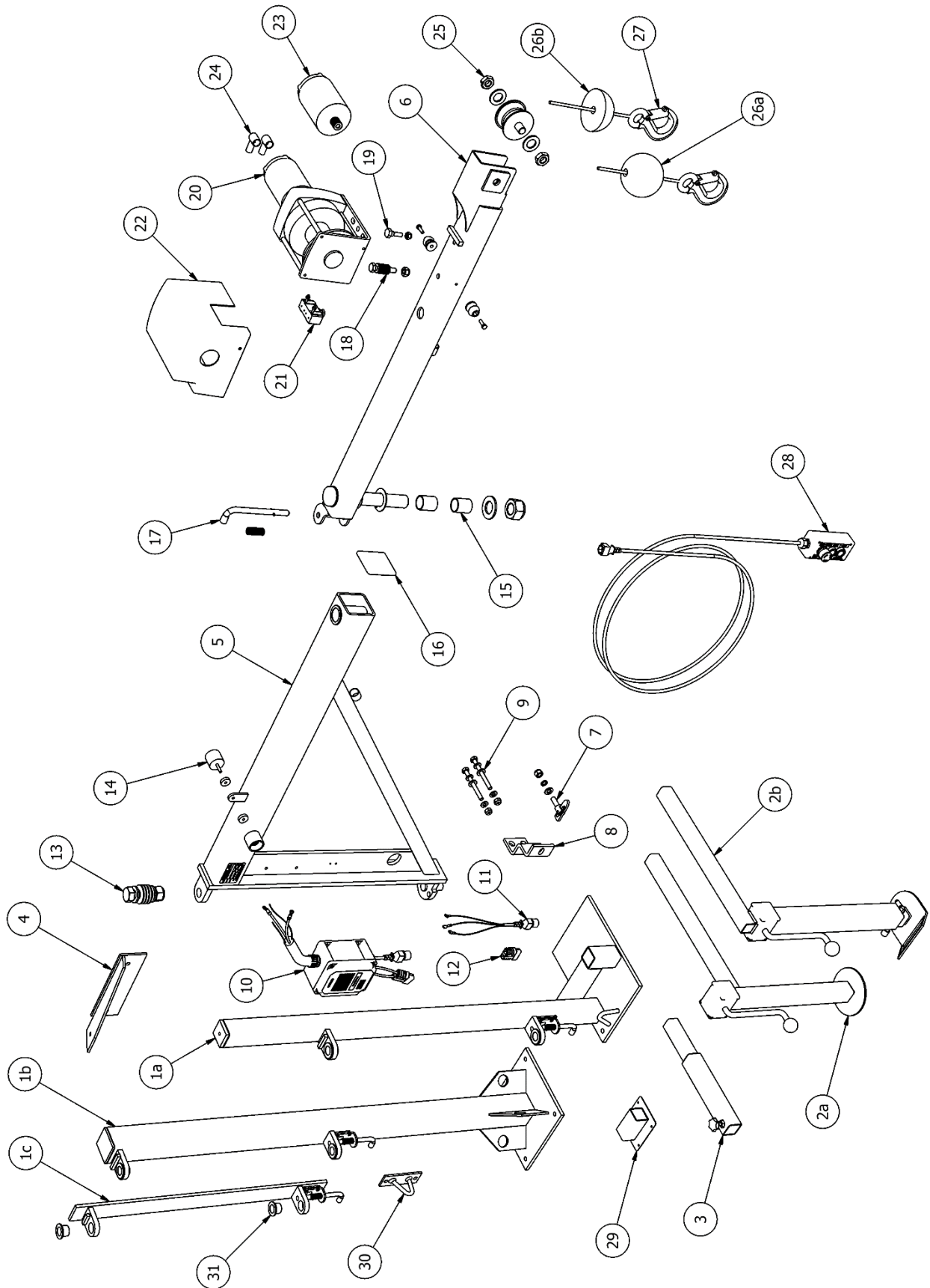

KJ250/2 – Parts List

ITEM	PART NUMBER	DESCRIPTION	QTY	
1	a	Subject to Specification	Van Pillar - Assembly	1
	b	541-000012	Combi Pillar - Assembly	1
	c	011-000346	Corner Bracket - Assembly	1
2	a	190-000006	Support Leg (2 Tier) - Assembly	1
	b	190-000015	Support Leg (3 Tier) - Assembly	1
3		503-000078	Leg Extension - Assembly	1
4		Subject to Specification	Top Mounting Bracket - Assembly	1
5		056-000317	Crane Body	1
6		056-000320	2nd Boom	1
7		064-000001	Antiluce Fastener - Assembly	1
8		011-000129	Antiluce Bracket	1
9		206-000001	Antiluce Fitting Kit	1
10	a	195-000010	Solenoid Box & Wiring Harness - 12V	1
	b	195-000011	Solenoid Box & Wiring Harness - 24V	1
11		547-000033	Remote Connector & Tail	1
12		108-000001	Anderson Power Connector - 50A	1
13		713-200008	Anti-slew Tensioner - Assembly	1
14		173-000006	Rubber Holder (Male & Female) - Assembly	1
15		035-000056	Joint Bearing - Assembly	1
16		547-000018	End Cap	1
17		079-000025	Shoot Bolt - Assembly	1
18		713-200005	Disc Spring - Assembly	1
19		200-000009	Shoulder Bolt - Assembly	1
20	a	077-000024	Winch Assembly - 12V - Left Hand (LH)	1
	b	077-000023	Winch Assembly - 12V - Right Hand (RH)	1
	c	077-000026	Winch Assembly - 24V - Left Hand (LH)	1
	d	077-000025	Winch Assembly - 24V - Right Hand (RH)	1
21		692-000008	Microswitch - Assembly	1
22	a	123-000035	Winch Cover - L/H	1
	b	123-000036	Winch Cover - R/H	1
23	a	614-000005	Winch Motor - 12V	1
	b	614-000007	Winch Motor - 24V	1
24		042-000001	Terminal Rubber Boot	2
25		555-000017	Pulley Wheel - Assembly	1
26	a	022-000002	Bob Weight - Assembly	1
	b	022-000004	Half Bob Weight - Assembly	1
27	a	079-000008	Rope 15' (4.5m) & Hook - Assembly	1
	b	079-000009	Rope 20' (6.0m) & Hook - Assembly	1
	c	079-000010	Rope 30' (9.1m) & Hook - Assembly	1
28		560-000016	Remote Control (3 Button Handset)	1
29		Subject to Specification	Support Leg Stowage Bracket - Assembly	1
30		079-000050	Rope Hook (Bulkhead Mounted) - Assembly	1
31		039-000002	Flanged Bush	2

KJ250/2 RPT – Exploded View

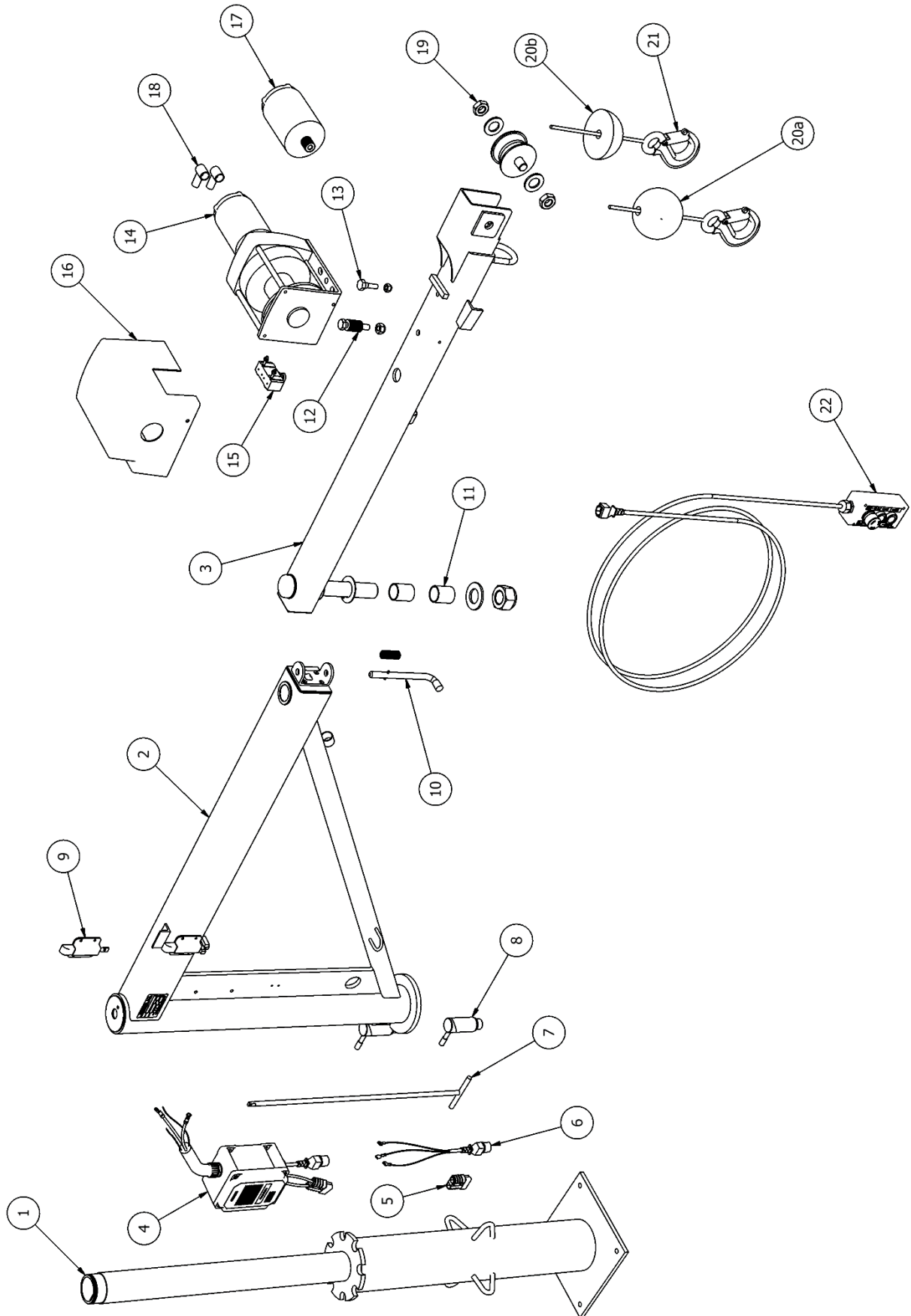

KJ250/2 RPT – Parts List

ITEM	PART NUMBER	DESCRIPTION	QTY
1	541-000011	Pillar - Assembly	1
2	056-000120	Crane Body	1
3	056-000123	2nd Boom	1
4	a 195-000010	Solenoid Box & Wiring Harness - 12V	1
	b 195-000011	Solenoid Box & Wiring Harness - 24V	1
5	108-000001	Anderson Power Connector - 50A	1
6	547-000033	Remote Connector & Tail	1
7	171-000019	Catch Handle	1
8	539-000045	Cam Lock	1
9	079-000023	Slam Latch	1
10	079-000025	Shoot Bolt - Assembly	1
11	035-000056	Joint Bearing - Assembly	1
12	713-200005	Disc Spring - Assembly	1
13	200-000009	Shoulder Bolt - Assembly	1
14	a 077-000024	Winch Assembly - 12V - Left Hand (LH)	1
	b 077-000023	Winch Assembly - 12V - Right Hand (RH)	1
	c 077-000026	Winch Assembly - 24V - Left Hand (LH)	1
	d 077-000025	Winch Assembly - 24V - Right Hand (RH)	1
15	692-000008	Microswitch - Assembly	1
16	a 123-000035	Winch Cover - L/H	1
	b 123-000036	Winch Cover - R/H	1
17	a 614-000005	Winch Motor - 12V	1
	b 614-000007	Winch Motor - 24V	1
18	042-000001	Terminal Rubber Boot	2
19	555-000017	Pulley Wheel - Assembly	1
20	a 022-000002	Bob Weight - Assembly	1
	b 022-000004	Half Bob Weight - Assembly	1
21	a 079-000008	Rope 15' (4.5m) & Hook - Assembly	1
	b 079-000009	Rope 20' (6.0m) & Hook - Assembly	1
	c 079-000010	Rope 30' (9.1m) & Hook - Assembly	1
22	560-000016	Remote Control (3 Button Handset)	1

Training Register

Health and safety legislation requires that all employers ensure all people using or supervising the use of work equipment have received adequate training in the method, risk and precautions.

Penny Hydraulics offers nationwide training by qualified instructors for the full range of lifting equipment. Training includes practical and theoretical input from the delegates with a certificate of competence issued on successful completion of the course.

Date	Trained operator	Signature	Trained by	Signature

Penny Hydraulics Ltd Standard Terms and Conditions (for the Supply of Goods and Services to non-consumers)

1 Interpretation

1.1 Definitions. In these Conditions, the following definitions apply:

Business Day: a day (other than a Saturday, Sunday or public holiday) when banks in London are open for business.

Conditions: the terms and conditions set out in this document as amended from time to time.

Confidential Information: all trade secrets, know-how, data, specifications, drawings, documents, techniques and technical data, processes, materials, apparatus and intellectual property of any kind whatsoever.

Contract: the contract between the Supplier and the Customer for the sale and purchase of the Goods and/or Services in accordance with these Conditions.

Customer: the person or entity who purchases the Goods and/or Services from the Supplier.

Force Majeure Event: has the meaning given in *clause 10*.

Goods: the goods (or any part of them) as set out in the Order/Order Acknowledgment.

Order: the Customer's order for the Goods and/or Services, as set out in the Customer's purchase order form OR in the Customer's acceptance of the Supplier's quotation as the case may be.

Order Acknowledgment: the Supplier's written acknowledgment of the Customer's purchase order.

Services: the services to be carried out by the Suppliers as per the Order/Order Acknowledgment.

Specification: any specification for the Goods and/or Services, including any related plans and drawings, that are agreed in writing by the Customer and the Supplier.

Supplier: Penny Hydraulics Ltd (registered in England and Wales with Company Number **01380206**).

1.2 Construction. In these Conditions, the following rules apply:

- (a) A person includes a natural person, corporate or unincorporated body (whether or not having separate legal personality).
- (b) A reference to a party includes its personal representatives, successors or permitted assigns.
- (c) A reference to a statute or statutory provision is a reference to such statute or provision as amended or re-enacted. A reference to a statute or statutory provision includes any subordinate legislation made under that statute or statutory provision, as amended or re-enacted.
- (d) Any phrase introduced by the terms including, include, in particular or any similar expression shall be construed as illustrative and shall not limit the sense of the words preceding those terms.
- (e) A reference to writing or written includes faxes and e-mails.

2 Basis of Contract

2.1 These Conditions apply to the Contract to the exclusion of any other terms that the Customer seeks to impose or incorporate, or which are implied by trade, custom, practice or course of dealing.

2.2 The Order constitutes an offer by the Customer to purchase the Goods and/or Services in accordance with these Conditions. The Customer is responsible for ensuring that the terms of the Order and any applicable Specification submitted by the Customer are complete and accurate.

2.3 The Order shall only be deemed to be accepted when the Supplier issues a written acceptance of the Order, at which point the Contract shall come into existence.

2.4 The Contract constitutes the entire agreement between the parties. The Customer acknowledges that it has not relied on any statement, promise or representation made or given by or on behalf of the Supplier which is not set out in the Contract.

2.5 Any samples, drawings, descriptive matter, or advertising produced by the Supplier and any descriptions or illustrations contained in the Supplier's catalogues or brochures are produced for the sole purpose of giving an approximate idea of the Goods and/or Services described in them. They shall not form part of the Contract or have any contractual force unless expressly stated to the contrary.

2.6 A quotation for the Goods and/or Services given by the Supplier shall not constitute an offer.

3 Goods

3.1 To the extent that the Goods are to be manufactured and/or installed in accordance with the Specification supplied by the Customer, the Customer shall indemnify the Supplier against all liabilities, costs, expenses, damages and losses (including any direct, indirect or consequential losses, loss of profit, loss of reputation and all interest, penalties and legal and other professional costs and expenses) suffered or incurred by the Supplier in connection with any claim made against the Supplier for actual or alleged infringement of a third party's intellectual property rights arising out of or in connection with the Supplier's use of the Specification. This *clause 3.1* shall survive termination of the Contract.

3.2 The Supplier reserves the right to amend the Specification if required by any applicable statutory or regulatory requirements.

4 Delivery

4.1 The Supplier shall deliver the Goods to the location set out in the Order or such other location as the parties may agree (Delivery Location) at any time after the Supplier notifies the Customer that the Goods are ready to be delivered.

4.2 Delivery of the Goods shall be completed on the Goods' arrival at the Delivery Location.

4.3 Any dates quoted for delivery of the Goods/the carrying out of the Services are approximate only, and the time is not of the essence. Whilst every effort will be made by the Supplier to deliver the Goods and/or carry out the Services on or before the date stated, no binding guarantee is given or implied and no claim will be accepted by the Supplier arising from or in connection with late delivery. Further, the Supplier shall not be liable for any loss or damage of any kind and howsoever arising by reason of any failure to deliver the Goods/carry out the Services on such stated dates.

4.4 The Supplier may deliver the Goods in more than one consignment even if not envisaged by the Order and/or Order Acknowledgment.

4.5 If the Supplier fails to deliver the Goods and/or perform the Services (in whole or part), its liability shall be limited to the costs and expenses incurred by the Customer in obtaining replacement Goods and/or Services of similar description and quality in the cheapest market available, less the price of the Goods and/or Services. The Supplier shall have no liability for any failure to deliver the Goods and/or Services to the extent that such failure is caused by a Force Majeure Event or the Customer's failure to provide the Supplier with adequate delivery instructions or any other instructions that are relevant to the supply of the Goods and/or Services.

4.6 If the Customer fails to take or accept delivery of the Goods or allow the Services to be performed within three Business Days of the Supplier notifying the Customer that the Goods/Services are ready to be delivered/performed, then, except where such failure or delay is caused by a Force Majeure Event or the Supplier's failure to comply with its obligations under the Contract:

- (a) delivery of the Goods/performance of the Services shall be deemed to have been completed at 9.00 am on the third Business Day after the day on which the Supplier notified the Customer that the Goods were ready for delivery/services ready to be performed and the Supplier will be entitled to invoice accordingly;

- (b) the Supplier shall store the Goods until any actual delivery takes place, and charge the Customer for all related losses, costs and expenses (including insurance); and
- (c) The Supplier will be entitled to charge the Customer for all related losses, costs and expenses caused as a result of having to re-schedule the performance of the Services.

4.7 If 10 Business Days after the day on which the Supplier notified the Customer that the Goods/Services were ready for delivery/performance the Customer has not taken or accepted delivery of the Goods/Services, the Supplier may resell or otherwise dispose of part or all of the Goods and, after deducting reasonable storage and selling costs, account to the Customer for any excess over the price of the Goods or charge the Customer for any shortfall below the price of the Goods. The Supplier would then be released from any obligation to perform the Services.

5 Quality

5.1 The Supplier warrants that on delivery, and for a period of 12 months from the date of delivery/performance (Warranty Period), the Goods and/or Services shall:

- (a) conform (in essence) with their description and the Specification;
- (b) be free from material defects in design, material and workmanship; and
- (c) be of satisfactory quality (within the meaning of the Sale of Goods Act 1979 and/or the supply of Goods and Services Act 1982); and
- (d) be fit for any purpose held out by the Supplier.

5.2 Subject to *clause 5.3*, if:

- (a) the Customer gives notice in writing to the Supplier during the Warranty Period and within a reasonable time of discovery (in any event no later than 14 days from discovery) that some or all of the Goods and/or Services do not comply with the warranty set out in *clause 5.1*;
- (b) the Supplier is given a reasonable opportunity of examining such Goods and/or Services; and
- (c) the Customer (if asked to do so by the Supplier) returns such Goods to the Supplier's place of business at the Supplier's cost, the Supplier shall, at its option, repair or replace the defective Goods and/or remedy any defective Services, or refund the price of the defective Goods and/or Services in full;
- (d) no defect in the Goods and/or Services is found for which the Supplier is liable, the Supplier shall be entitled to compensation (on an indemnity basis) for the costs he has incurred as a result of the notice.

5.3 The Supplier shall not be liable for any failure to comply with the warranty set out in *clause 5.1* in any of the following events:

- (a) the Customer makes any further use of such Goods after giving notice in accordance with *clause 5.2*;
- (b) the defect arises because the Customer failed to follow the Supplier's oral or written instructions as to the storage, commissioning, installation, use and maintenance of the Goods or (if there are none) good trade practice regarding the same;
- (c) the defect arises as a result of the Supplier following any drawing, design or Specification supplied by the Customer;
- (d) the Customer alters or repairs such Goods without the written consent of the Supplier;
- (e) the defect arises as a result of fair wear and tear, wilful damage, negligence, or abnormal storage or working conditions; or
- (f) the Goods and/or Services differ from their description or the Specification as a result of changes made to ensure they comply with applicable statutory or regulatory requirements.

5.4 Except as provided in this *clause 5*, the Supplier shall have no liability to the Customer in respect of any failure to comply with the warranty set out in *clause 5.1*.

5.5 The terms implied by sections 13 to 15 of the Sale of Goods Act 1979 and Section 4 of the Supply of Goods and Services Act 1982 are, to the fullest extent permitted by law, excluded from the Contract.

5.6 These Conditions shall apply to any repaired or replacement Goods or remedied Services supplied by the Supplier.

6 Title and Risk

6.1 The risk in the Goods shall pass to the Customer on completion of delivery. The delivery of Goods by the Supplier to a carrier consigned to the Customer shall constitute complete transfer of responsibility to the Customer with said carrier thereafter acting on the Customer's behalf. Notwithstanding and without prejudice to the above provision, no claim for damages in transit, shortage of delivery or loss of Goods in transit can be made by the Customer against the Supplier unless:

- (i) the issue has without any doubt been caused before the Goods were supplied by the Supplier to the carrier consigned to the Customer;
- (ii) in the case of damage in transit or shortage of delivery, a separate notice in writing is given to the carrier concerned and to the Supplier within 3 days of receipt of Goods followed by a complete claim in writing within 5 days of receipt of Goods.

6.2 As soon as the Goods or any part thereof have been delivered the Goods or that part shall be at the risk of the Customer who shall insure the Goods for the period from the date of delivery until the passing of the property in the Goods to the Customer against any loss of or damage thereto or any part thereof except in those instances where the selling price of the Goods includes installation when the Goods will remain at the Supplier's risk and insured by the Supplier until they have been installed or up to 30 days from the date of delivery whichever shall be the sooner.

6.3 Title to the Goods shall not pass to the Customer until the Supplier has received payment in full (in cash or cleared funds) for;

- (a) The Goods; and
- (b) any other goods or Services that the Supplier has supplied to the Customer in respect of which payment has become due.

6.4 Until title to the Goods has passed to the Customer, the Customer shall:

- (a) hold the Goods on a fiduciary basis as the Supplier's bailee;
- (b) store the Goods separately from all other goods held by the Customer so that they remain readily identifiable as the Supplier's property;
- (c) not remove, deface or obscure any identifying mark or packaging on or relating to the Goods;
- (d) maintain the Goods in satisfactory condition and keep them insured against all risks for their full price from the date of delivery;
- (e) notify the Supplier immediately if it becomes subject to any of the events listed in *clause 8.2*; and
- (f) give the Supplier such information relating to the Goods as the Supplier may require from time to time,
- (g) shall keep and retain the delivered Goods free from any charge lien or other encumbrance thereon.

6.5 If before title to the Goods passes to the Customer the Customer becomes subject to any of the events listed in *clause 8.2*, or the Supplier reasonably believes that any such event is about to happen and notifies the Customer accordingly, then without limiting any other right or remedy the Supplier may have, the Supplier may at any time require the Customer to deliver up the Goods and, if the Customer fails to do so promptly, enter any premises of the Customer (the Customer hereby irrevocably grants to the Supplier a licence for that purpose) or of any third party where the Goods are stored in order to recover them.

6.6 The Customer irrevocably accepts that if Goods are capable of being removed by unbolting (or howsoever) so as not to structurally damage the fabric of the building in which they reinstalled/stored they will be deemed to be easily removable, in their original state and not incorporated into the fabric of such said building.

6.7 The provisions of Title & Risk shall survive the termination of the Contract for whatever reason and in particular, but without limitation, termination of the Contract by the Supplier by the acceptance of any repudiation of the Contract by the Customer.

6.8 The Supplier shall be entitled to exercise a general lien or right of retention on all Goods or any parts thereof in the Supplier's possession which are the Customer's property (or which are supplied to the Supplier by the Customer) for any sums whatsoever due to the Supplier and pursuant to such lien or right the Supplier shall be entitled, without notice to the Customer, to sell all or any part of such Goods/property privately or by auction or otherwise and to keep the proceeds of sale in diminution of such sums and of all costs and expenses incurred by the Supplier in effecting the said sales. Any balance remaining thereafter shall be remitted to the Customer by the Supplier. Upon such sale title in the said Goods/property shall pass to the buyer thereof.

7 Price and Payment

7.1 The price of the Goods and/or Services shall be the price set out in the Quotation, Order or Order Acknowledgment (whichever is the latter).

7.2 The Supplier may at any time before delivery/performance, increase the price of the Goods and/or Services to reflect any increase in the cost of the Goods/Services that is due to:

- (a) any factor beyond the Supplier's control (including foreign exchange fluctuations, increases in taxes and duties, increases in line with the consumer price index (CPI) and increases in labour, materials and other manufacturing costs);
- (b) any request by the Customer to change the delivery/performance date(s), quantities or types of Goods/Services ordered, or the Specification; or
- (c) any delay caused by any instructions of the Customer or failure of the Customer to give the Supplier adequate or accurate information or instructions.

7.3 The price of the Goods is exclusive of the costs and charges of packaging, insurance and transport of the Goods (unless stated otherwise), which shall be invoiced to the Customer.

7.4 The price of the Goods/Services is exclusive of amounts in respect of value added tax (unless stated otherwise). The Customer shall, upon receipt of a valid VAT invoice from the Supplier, pay to the Supplier such additional amounts in respect of VAT as are chargeable on the supply of Goods/Services.

7.5 The Supplier may invoice the Customer for the Goods and Services on or at any time after the completion of delivery/performance.

7.6 The Customer shall pay the invoice in full and in cleared funds on or before the date(s) stipulated in the Quotation/Order Acknowledgment or other such document and in the event of such not being stipulated therein within 30 days of the date of the invoice. Time of payment is of the essence.

7.7 Should the Customer fail to pay the said price or any part thereof within the said period of 30 days or on the date specified in writing the Customer shall pay interest on all amounts outstanding in respect thereof at the rate of 1.5% per month such interest to be compounded and added to the amount outstanding monthly until payment such interest to be chargeable from the date due for payment until payment of all amounts outstanding in respect of the price and such interest. If any payment is in arrears for or on account of or in respect of any Goods and/or Services delivered under this or any other contract between the Supplier and the Customer the Supplier shall have the absolute right without giving any notice to the Customer to suspend further deliveries and services under this or any other such contract and if any such payment or any part thereof shall remain in arrears for seven days after written demand by the Supplier to the Customer the Supplier shall have the right to cancel this and any other such contract without prejudice to all its rights and remedies to recover any monies due and owing from the Customer.

7.8 The Customer will indemnify the Supplier in respect of all/any costs that the Supplier incurs in recovering any debts against the Customer on a full indemnity basis. Further, the Customer will indemnify the Supplier and hold it harmless against all/any claims made by third parties with regard to the Goods and Services supplied.

7.9 The Customer shall pay all amounts due under the Contract in full without any deduction or withholding except as required by law and the Customer shall not be entitled to assert any credit, set-off or counterclaim against the Supplier in order to justify withholding payment of any such amount in whole or in part. The Supplier may at any time, without limiting any other rights or remedies it may have, set off any amount owing to it by the Customer against any amount payable by the Supplier to the Customer.

7.10 Any deposit(s) paid by the Customer to the Supplier will be non-refundable unless expressly stated to the contrary.

8 Customer's Insolvency or Incapacity

8.1 If the Customer becomes subject to any of the events listed in *clause 8.2*, or the Supplier reasonably believes that the Customer is about to become subject to any of them and notifies the Customer accordingly, then, without limiting any other right or remedy available to the Supplier, the Supplier may cancel or suspend all further deliveries under the Contract or under any other contract between the Customer and the Supplier without incurring any liability to the Customer, and all outstanding sums in respect of Goods and/or Services delivered to the Customer shall become immediately due.

8.2 For the purposes of *clause 8.1*, the relevant events are:

- (a) the Customer suspends, or threatens to suspend, payment of its debts, or is unable to pay its debts as they fall due or admits inability to pay its debts, or (being a company) is deemed unable to pay its debts within the meaning of section 123 of the Insolvency Act 1986, or (being an individual) is deemed either unable to pay its debts or as having no reasonable prospect of so doing, in either case, within the meaning of section 268 of the Insolvency Act 1986, or (being a partnership) has any partner to whom any of the foregoing apply;
- (b) the Customer commences negotiations with all or any class of its creditors with a view to rescheduling any of its debts or makes a proposal for or enters into any compromise or arrangement with its creditors.
- (c) (being a company) a petition is filed, a notice is given, a resolution is passed, or an order is made, for or in connection with the winding up of the Customer, other than for the sole purpose of a scheme for a solvent amalgamation of the Customer with one or more other companies or the solvent reconstruction of the Customer;
- (d) (being an individual) the Customer is the subject of a bankruptcy petition or order or if in Scotland he shall become insolvent or natour bankrupt.
- (e) a creditor or encumbrancer of the Customer attaches or takes possession of, or a distress, execution, sequestration or other such process is levied or enforced on or sue against, the whole or any part of its assets and such attachment or process is not discharged within 14 days;
- (f) (being a company) an application is made to court, or an order is made, for the appointment of an administrator or if a notice of intention to appoint an administrator is given or if an administrator is appointed over the Customer;
- (g) (being a company) a floating charge holder over the Customer's assets has become entitled to appoint or has appointed an administrative receiver;
- (h) a person becomes entitled to appoint a receiver over the Customer's assets or a receiver is appointed over the Customer's assets;
- (i) any event occurs, or proceeding is taken, with respect to the Customer in any jurisdiction to which it is subject that has an effect equivalent or similar to any of the events mentioned in *clause 8.2(a) to clause 8.2(h)* (inclusive);
- (j) the Customer suspends, threatens to suspend, ceases or threatens to cease to carry on all or substantially the whole of its business;
- (k) the Customer's financial position deteriorates to such an extent that in the Supplier's opinion the Customer's capability to adequately fulfil its obligations under the Contract has been placed in jeopardy; and

- (l) (being an individual) the Customer does or, by reason of illness or incapacity (whether mental or physical), is incapable of managing his or her own affairs or becomes a patient under any mental health legislation.

8.3 Termination of the Contract, however arising, shall not affect any of the parties' rights and remedies that have accrued as at termination. Clauses which expressly or by implication survive termination of the Contract shall continue in full force and effect.

9 Limitation of Liability

9.1 Nothing in these Conditions shall limit or exclude the Supplier's liability for:

- (a) death or personal injury caused by its negligence or the negligence of its employees.
- (b) fraud or fraudulent misrepresentation;
- (c) any matter in respect of which it would be unlawful for the Supplier to exclude or restrict liability.

9.2 To the extent, however, that it is lawful to do so, the Supplier excludes its liability as follows:

- (a) the Supplier shall under no circumstances whatever be liable to the Customer, whether in contract, tort (including negligence), breach of statutory duty, or otherwise, for any loss of profit, or any indirect or consequential loss arising under or in connection with the Contract and/or the supply of Goods and/or Services to the Customer;
- (b) the Supplier's total liability to the Customer in respect of all losses arising under or in connection with the Contract, whether in contract, tort (including negligence), breach of statutory duty, or otherwise, shall in no circumstances exceed the price of the Goods and/or Services.

10 Force Majeure

10.1 The Supplier shall be entitled to suspend performance of its obligations under the contract to the extent that such performance is impeded or made unreasonably onerous by any of the following circumstances: industrial disputes and any other circumstances beyond the control of the parties such as fire, war (whether declared or not), extensive military mobilisation, insurrection, requisition, seizure, embargo, restrictions in the use of power and effects or delays in deliveries or performance by sub-contractors or suppliers.

10.2 Regardless of what might otherwise follow from these Conditions, either party shall be entitled to terminate the contract by notice in writing to the other party if performance of the contract is suspended under Clause 10.1 for more than 3 months.

11 General

11.1 Assignment and subcontracting.

- (a) The Supplier may at any time assign, transfer, charge, subcontract or deal in any other manner with all or any of its rights or obligations under the Contract.
- (b) The Customer may not assign, transfer, charge, subcontract or deal in any other manner with all or any of its rights or obligations under the Contract without the prior written consent of the Supplier.

11.2 Intellectual Property.

- (a) All Confidential Information relating to the Goods or their manufacture submitted by the Supplier to the Customer, prior or subsequent to the formation of the contract shall remain the property of the Supplier and the Customer will keep the Confidential Information secret, unless disclosure of the Confidential Information is required by a Court of competent jurisdiction. The Confidential Information shall not, without the consent of the Supplier, be used for any other purpose than erection, installation, commissioning, operation or maintenance of the Goods.

- (b) The Customer will neither itself, nor through any agent or other manufacturer interfere with the business of the Supplier nor to supply or manufacture whether on its own or in conjunction with others any goods or products of a similar nature to the Goods supplied to the Customer for a period of 3 years from the date of the last supply of Goods by the Supplier to the Customer.
- (c) For the avoidance of doubt the Customer will not at any time divulge or allow to be divulged to any person any Confidential Information relating to the Goods including any drawings, specifications, technical information or designs and will not cause or permit anything which may damage or endanger the Supplier's intellectual property in the Goods or to use for its own purposes or to divulge to any third party any Confidential Information.
- (d) The Customer will indemnify the Supplier against any damage or loss occasioned by any breach of this clause 11 including, without limitation, consequential losses, loss of profit and all legal and other professional costs.

11.3 Notices.

- (a) Any notice or other communication given to a party under or in connection with the Contract shall be in writing, addressed to that party at its registered office (it is a company) or its principal place of business (in any other case) or such other address as that party may have specified to the other party in writing in accordance with this clause, and shall be delivered personally, sent by pre-paid first class post, recorded delivery, commercial courier, fax or e-mail.
- (b) A notice or other communication shall be deemed to have been received: if delivered personally, when left at the address referred to in *clause 11.3(a)*; if sent by pre-paid first class post or recorded delivery, at 9.00 am on the second Business Day after posting; if delivered by commercial courier, on the date and at the time that the courier's delivery receipt is signed; or, if sent by fax or e-mail, one Business Day after transmission.
- (c) The provisions of this clause shall not apply to the service of any proceedings or other documents in any legal action.

11.4 Severance.

- (a) If any court or competent authority finds that any provision of the Contract (or part of any provision) is invalid, illegal or unenforceable, that provision or part-provision shall, to the extent required, be deemed to be deleted, and the validity and enforceability of the other provisions of the Contract shall not be affected.
- (b) If any invalid, unenforceable or illegal provision of the Contract would be valid, enforceable and legal if some part of it were deleted, the provision shall apply with the minimum modification necessary to make it legal, valid and enforceable.

11.5 Waiver.

A waiver of any right or remedy under the Contract is only effective if given in writing and shall not be deemed a waiver of any subsequent breach or default. No failure or delay by a party to exercise any right or remedy provided under the Contract or by law shall constitute a waiver of that or any other right or remedy, nor shall it preclude or restrict the further exercise of that or any other right or remedy. No single or partial exercise of such right or remedy shall preclude or restrict the further exercise of that or any other right or remedy.

11.6 Third party rights.

A person who is not a party to the Contract shall not have any rights under or in connection with it.

11.7 Variation.

Except as set out in these Conditions, any variation to the Contract, including the introduction of any additional terms and conditions, shall only be binding when agreed in writing and signed by the Supplier.

11.8 Governing law and jurisdiction.

The Contract, and any dispute or claim arising out of or in connection with it or its subject matter or formation (including non-contractual disputes or claims), shall be governed by, and construed in accordance with, English law, and the parties irrevocably submit to the exclusive jurisdiction of the courts of England and Wales.