



TECHNICAL DOCUMENT

CT-15 – DUAL WIRE HOIST

KEY FEATURES:

- LIFTING LOADS UP TO 15 KG / 33 LBS
- MAXIMUM LOWERING DISTANCE 10 M / 32 FT
- SAFETY LOCKING DEVICE
- WIRELESS REMOTE CONTROL (OPTIONAL)
- PRE-WIRED TERMINALS

LIFT APPLICATIONS:

- LIGHTING
- CCTV
- FIRE DETECTION SYSTEMS
- DISPLAYS / BANNERS
- AUDIO / VISUAL / DATA SYSTEMS



Contents

Contents.....	2
Product overview.....	3
Key Features	4
Automatic secondary support device	4
Electrical contact plates.....	4
Technical Specification	5
Dimensions	6
Wiring Diagram	6
Control Options.....	7
Wireless control (optional - recommended)	7
Hardwired control (optional).....	7
Mounting Options.....	8
Mounting Bracket (optional)	8
Suspension Eye	8
Installation Guidelines	8
Installation Method	9
Optional Accessories.....	10

Product overview

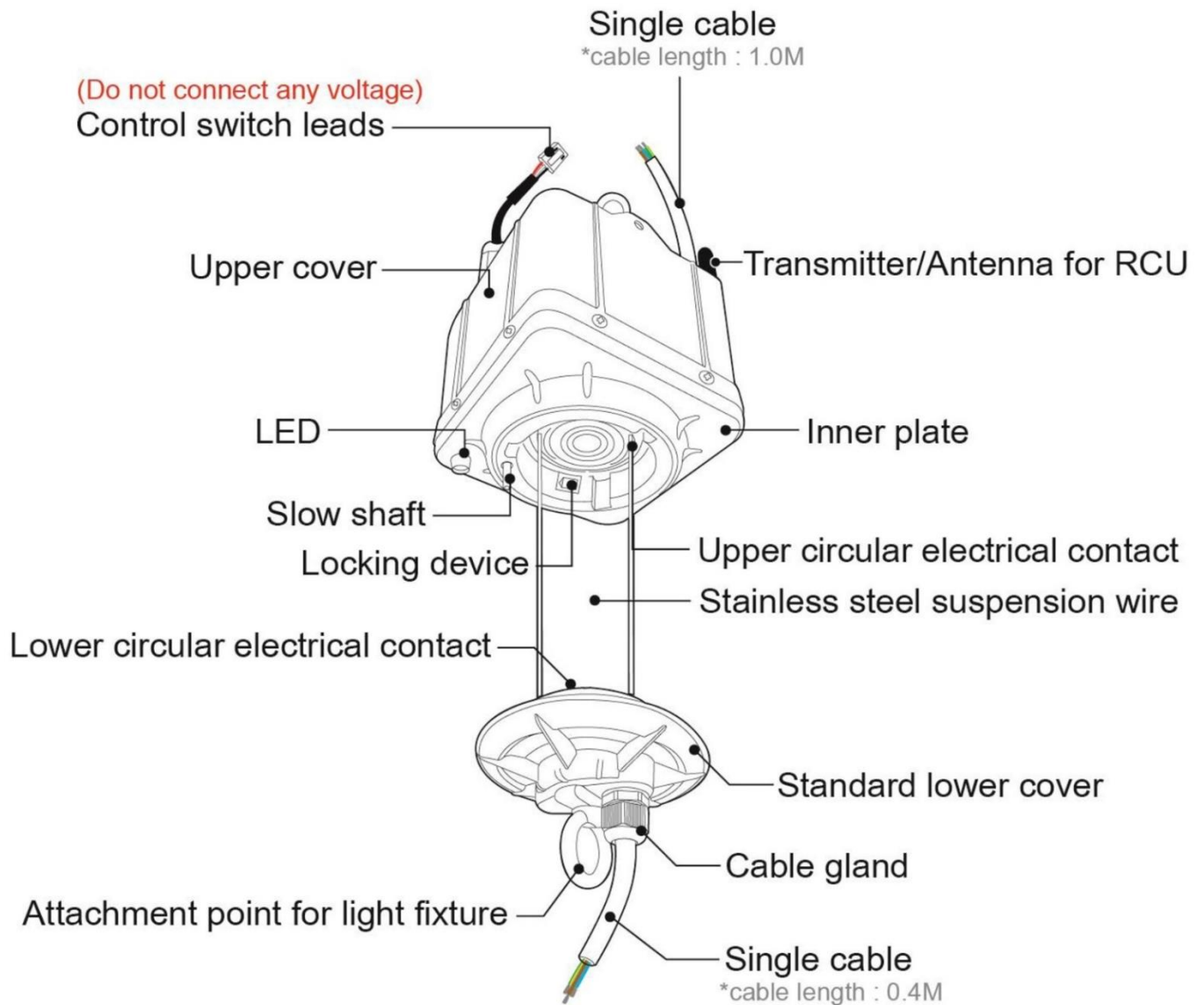

Key Features

Lifting capacity

3 kg / 6.6 lbs (min) – 15 kg / 33 lbs (max)

Maximum Lowering distance

10 m / 32 ft

Lighting power capacity

1 circuit, 16 amp

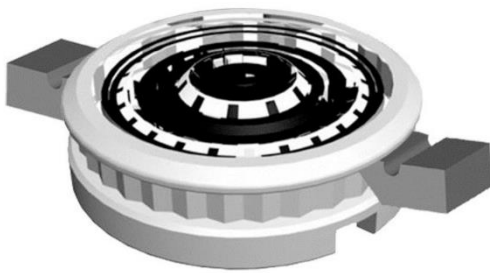

Automatic secondary support device

The automatic secondary support device engages when the light fitting is at rest at high level.

Special safety locking jaws mate onto the lowering part of the hoist and relieve the hoist motor and wire rope from tension.

This process is fully automated, so the user does not have any complicated instructions to memorise to engage the mechanism. Simply press the Up button until the hoist system is docked and mechanically locked-off at high level.

Electrical contact plates

Electrical connection between the main lighting supply and the light fitting suspended from the hoist is by way of spring loaded contact plates within the main body of the hoist (the part fixed to the ceiling structure) and fixed contacts on the lowering section of the hoist (the part that raises and lowers with the light fitting).

Upon lowering, the hoist automatically initiates an internal relay that isolates the electrical supply feeding the contacts. When the light fitting is fully raised, the relay returns power to the contacts and energises the light fitting.

The light fitting is fully isolated when down at ground level which provides an added element of safety for the user working on/maintaining the light fitting.

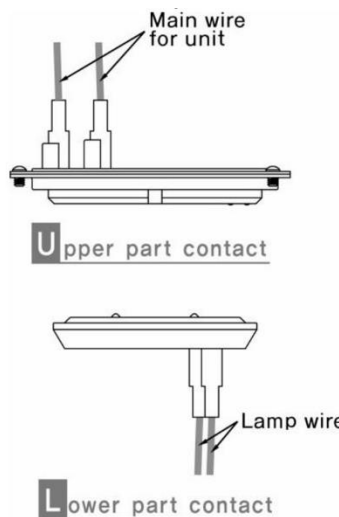

Technical Specification

Brand	Penny Hydraulics Ltd
Product ID	CT-15
Type	Compact
Option	Standard
Operating Voltage	230v 50Hz, 120v 60Hz – others operating voltages available - specify requirements on enquiry
Wattage	25 w
Unit dimensions	140 mm x 140 mm x 216 mm / 5.5" x 5.5" x 8.5"
Unit net weight	3.1 kg / 6.8 lbs
Packed dimensions	175 mm x 175 mm x 245 mm / 6.8" x 6.8" x 9.6"
Packaged weight	3.4 kg / 7.5 lbs
Ambient operating temperature	-15° to 40°C
Lifting capacity	3 kg / 6.6 lbs (minimum) – 15 kg / 33 lbs (maximum)
Max lowering distance	10 m / 32 ft
Raising/lowering speed	1-1.9 m/min (3.2-6.2 ft/min)
No of circuits	1
No of contacts	2
Lamp capacity	16 amp
Protection rating	Standard IP54, increase to IP65 with optional CT-C exterior cover
Suspension wire dia	1.2 mm
Colour	Standard – white, bespoke colours available on request
Certification	ISO9001, ISO14001, ETL, CE, TUV, SAA, GOST

Dimensions

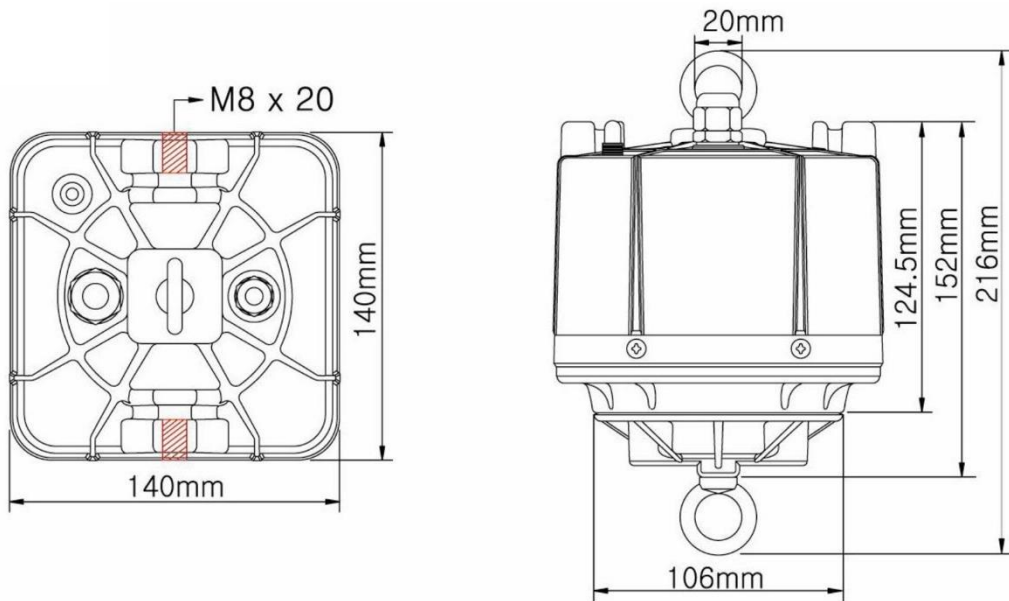

Wiring Diagram

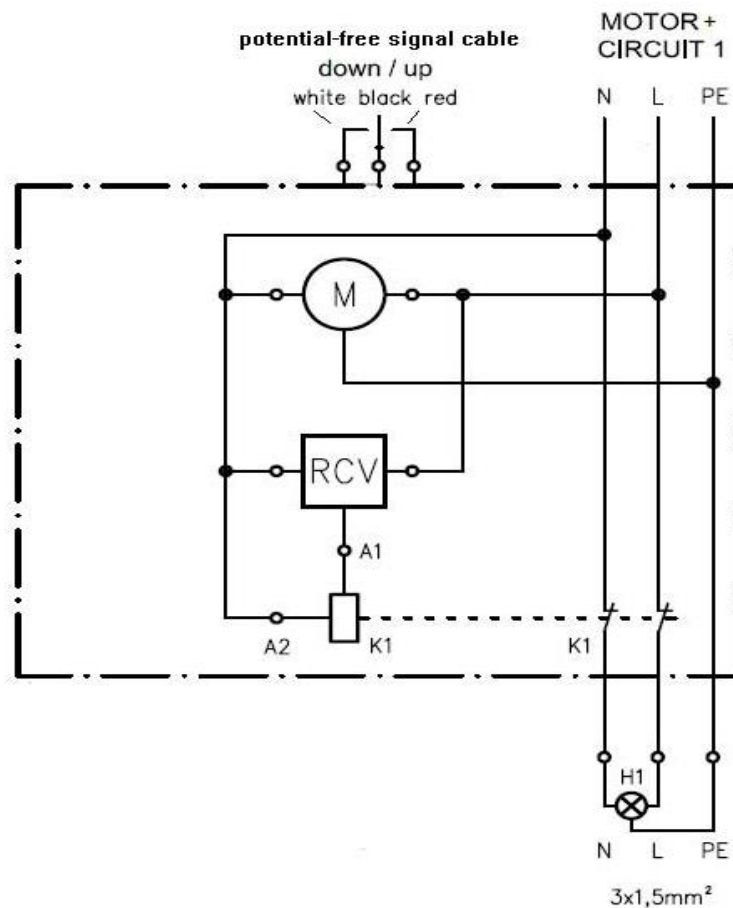

Control Options

Wired or wireless controls are not included as standard with a self-contained hoist and must be purchased as an optional extra.

Wireless control (optional - recommended)



Capacity:	Control up to 999 lift addresses, group lifts – up to 999 groups
Frequency:	licence-free ISM band 433.92MHz
Range:	up to 100 m / 328 ft
Size:	105 mm x 50 mm / 4.1" x 1.6"
Functions:	Programmable auto-stop position for lift.
Material:	Plastic enclosure
Colour:	Light Grey
Power:	3x 1.5v alkaline AAA batteries

Hardwired control (optional)

3-core cable between hoist and switch not included.

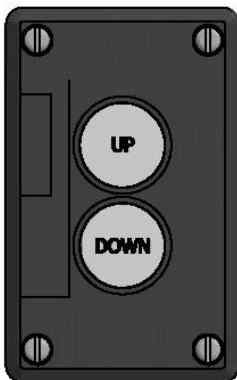

Functions:	2 function enclosure
Switches:	2 x N/O push button switches, marked 'UP', 'DOWN'.
Size:	106 mm x 68 mm x 53 mm / 4.2" x 2.6" x 2"
IP rating:	IP67
Material:	Polycarbonate
Colour:	Dark grey (face), Light grey (base)
Ambient operating temperature:	-40 to 70 °C
Supplied with:	1 x M20 cable gland

Mounting Options

Mounting Bracket (optional)

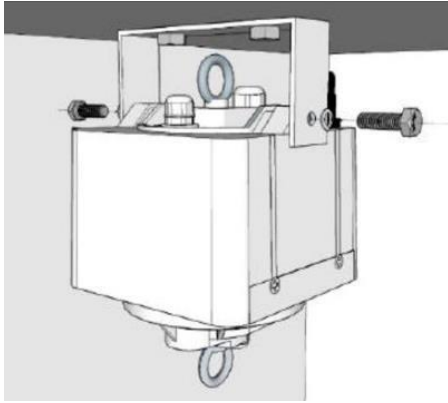

Hoist can be rigidly secured to building structure via a bolted, u-shaped ceiling bracket.

Suspension Eye

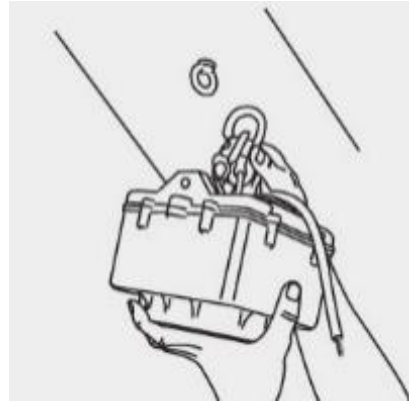

Hoist can be hung directly from the attachment eye on the top of the hoist body. A secondary safety tether is required if this fixing method is used.

Installation Guidelines



Always ensure appropriately qualified electrical personnel wire hoist units.



Do not lower hoist further than maximum lowering distance. This could damage hoist and void warranty.



Do not operate hoist without the minimum weight specified.



Always install hoist in unit code order. Hoists are all numbered on the side of unit.



When installing multiple units, ensure layout is mapped and associated unit serial numbers are documented to aid with operation and problem solving in the future.



The hoist must be fixed with suitable fixings to a mechanically safe and sound surface capable of withstanding the combined load of the light fitting and hoist. If in doubt, consult a structural engineer.

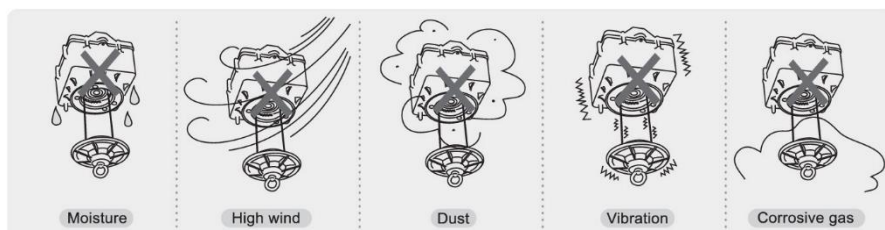

Avoid installing where there is high moisture, high wind, excessive dust, vibration and/or corrosive gas.

Installation Method

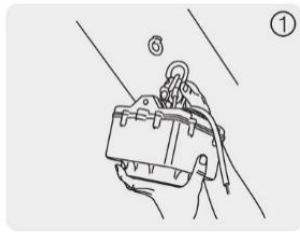

Attach hoist with a rated lifting shackle and secondary support tether or optional installation bracket to ceiling structure.

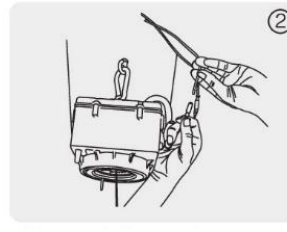
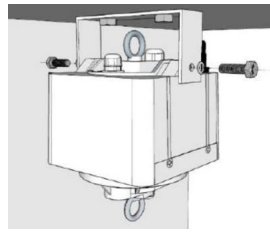

Connect the mains power to the hoist, and control switch leads to the hardwired control box (if applicable).

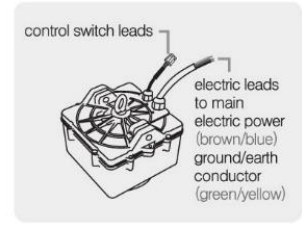

At this point, ensure the system is thoroughly examined and commissioned by a competent person prior to installing the load.

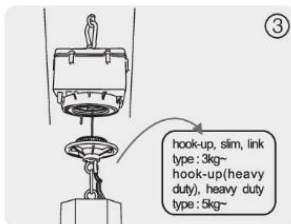

Attach light fitting to the connection point on the underside of the hoist.

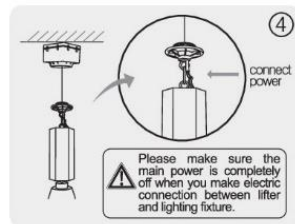

Make electrical connection from lowering part of hoist to light fitting.

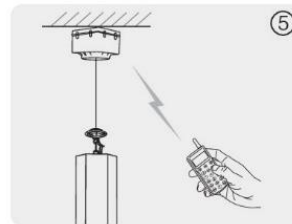

Press down function button on RCU or hardwired control box to lower fitting.

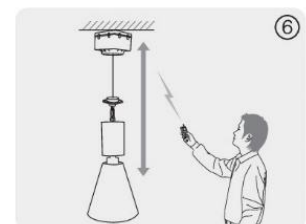

Test the hoist through its full range of operation and set lower limit to avoid light fitting contacting floor (this feature only available with RCU).

Optional Accessories

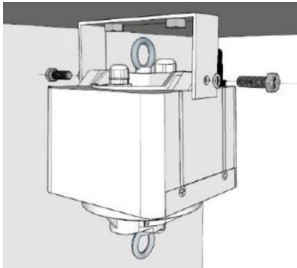

CT-MB
U-shaped bracket used to securely mount the lift to the ceiling substrate using two fixing points

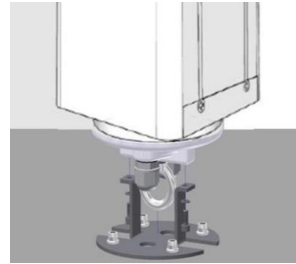

C-MB
Ideal for the mounting of round ceiling rose type fixture bases or pendant mounts to the lowering part of the hoist.



RP-MB
A 400mm (15.7") diameter ceiling plate used to conceal the lift from view when recessed behind a suspended ceiling or plaster soffit.

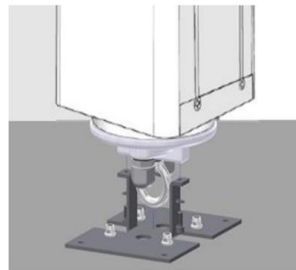

R-MB
Ideal for the mounting of square or rectangular type fittings and fixtures directly to the lowering part of the hoist.



CT-C
When using self-contained hoists in extreme environments (dusty, wet, corrosive), increase the IP rating from IP54 to IP65 with this exterior cover including integrated ceiling mounting bracket.



Hardwired control box
A 2-function enclosure with 2 x N/O buttons labelled 'UP' and 'DOWN' mounted to the face. 3-core cable between the hoist and control box not provided with the control box.



RCU
Wireless radio remote control used to control up to 999 lift addresses in upto 999 groups.