



GoodsLift

Mezzanine GoodsLifts | CellarLifts | BayLifts | LightwellLifts

Contents

GoodsLift Overview	03
MezzLight HandLoaded 250kg GoodsLift	05
MezzLight 250kg GoodsLift	07
MezzLight 3 Tier 250kg GoodsLift	09
MezzPro 500kg GoodsLift	11
MezzPro 3 Tier 500kg GoodsLift	13
MezzHD 1000kg GoodsLift	15
MezzHD 3 Tier 1000kg GoodsLift	17
LightwellLifts	19
CellarLift	20
Vertical CellarLift	21
Sloping CellarLift	23
CaseHoists	25
BayLift	26
We've Got You Covered	27
Case Study	28
Customer Feedback	29
Penny Hydraulics HQ & Your Local Engineer	30



Penny Hydraulics GoodsLifts. Designed and manufactured in the UK.

Penny Hydraulics mezzanine floor GoodsLifts are designed and manufactured in the UK at our purpose built facility in North Derbyshire.

Quotation

We can be contacted by phone or email. If you can provide us information on the size and weight of the items being transported and some details on the location of the lift; the floor to floor height and any space restrictions we can offer a fixed priced quotation and site specific drawings.

Design

Using the latest 3D Computer-Aided Design (CAD) software, we model every project on-screen which can be provided to customers in a range of formats including AutoCAD drawings, PDF, 3D PDF or CAD models. Our customers can also use these models to envisage the solution and aid with the communication of ideas when speaking to stakeholders or other contractors. This also allows us to have BIM content readily available.

Site Survey

We offer free site surveys nationwide to discuss the detailed requirements of the lift and measure the intricacies of the lift location.

Manufacture

One of our competitive advantages is that we manufacture our equipment at our purpose-built facility in Derbyshire. This allows us to offer our customers short lead times, high-quality standards, and bespoke features.

Our agile manufacturing capability enables us to make design changes and model options late into the manufacturing process often without affecting lead time or price.

With a problem-solving mentality, we use a combination of intelligent design and experience to manufacture a tailor-made solution that enables you to work smarter.

Installation

We boast a team of specialist engineers fully trained and ready to install equipment at customer sites throughout the UK. By choosing Penny Hydraulics to install your equipment, you can ensure correct and safe installation and minimise downtime.

Aftercare

Once you have your Penny Hydraulics equipment, we provide a comprehensive aftercare process comprising of operator familiarisation and servicing packages, arming you with complete knowledge about your product and its capabilities. As well as scheduled preventative maintenance visits, statutory Thorough Examinations can also be carried out, so you can trust Penny Hydraulics to provide a solution that can be relied on for years.

The Green Deal

Penny Hydraulics was an early adopter of green strategies. As well as being good for the planet they generally make sound business sense. 50% of the factory power is from solar energy. Waste reduction and recycling keeps our costs down. All our designs are built to be maintained. We have 30 year old lifts working as they did when new but if a product has to be decommissioned we will always take it back to be stripped and recycled.

Did you know?

Penny Hydraulics have all of our lifting products available to view on NBS. Visit us on the NBS Portal to find detailed information and technical drawings of our GoodsLifts.



MezzLight HandLoaded 250kg GoodsLift >

The MezzLight Handloaded Lifts are the most cost-effective arrangement, enabling users to move goods such as boxes and crates safely and efficiently to secondary storage areas within buildings. With the platform docking at 950mm above the finished floor height at both landings items are easily loaded on and off by hand.

Features

- Floor mounted, no pit required
- Self- supporting mesh-clad shaft
- Platform docks 950mm above finished floor level
- Constant pressure control buttons at both levels
- 250kg Maximum Working Load
- Standard travel height up to 4m
- Standard usable platform size 1000mm x 800mm
- Same side or through car loading
- 2 stops (ground plus one level)
- Both level gates fitted with electrical and mechanical interlocks
- Emergency stop button
- BIM Content Available



Options

- Bespoke platform sizes
- Bespoke docking height
- Increased travel height (up to 9m)
- Up to 3 stops (ground plus two additional levels)
- Outside installation
- Choice of finish colour
- 90° loading or additional entrances
- Fully clad enclosure



Technical Specifications – MezzLight HandLoaded 250kg GoodsLift

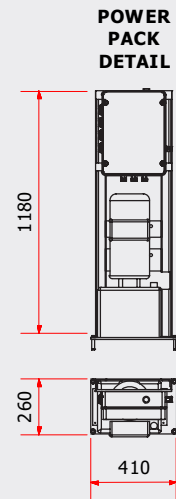
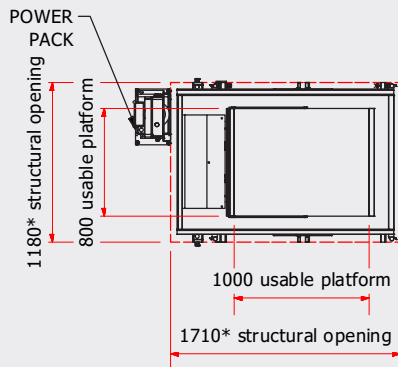
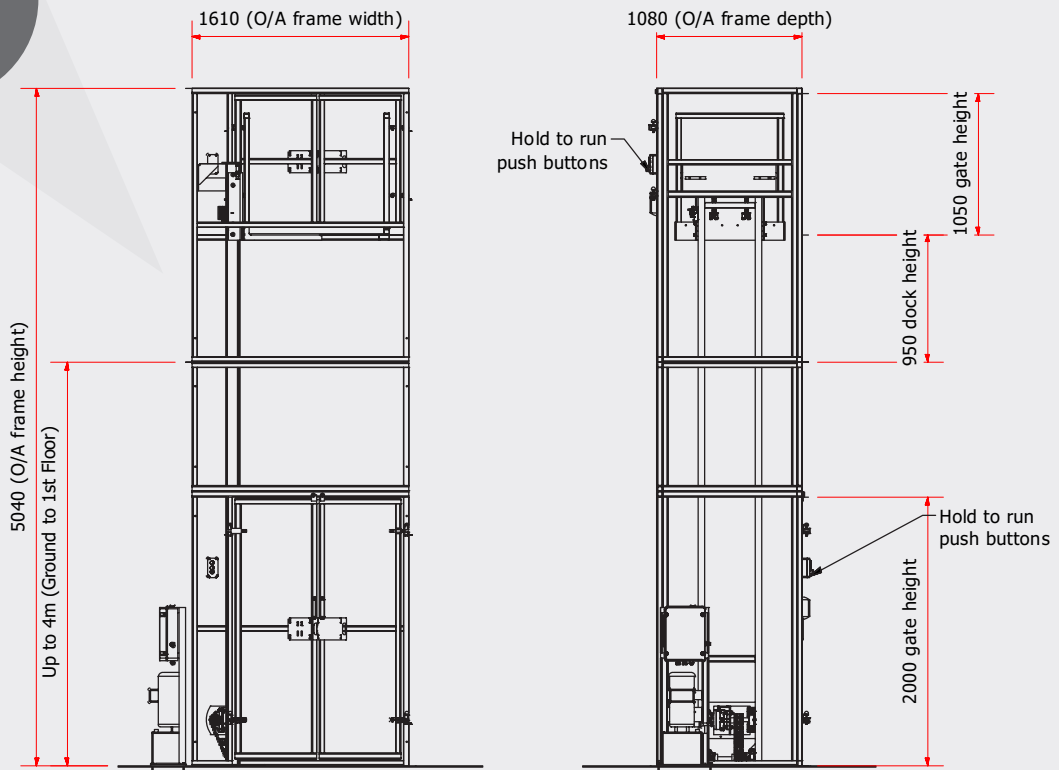

Power Supply

240 V, 20 A, 1ph terminated in a double pole isolator at lower level.

Construction

All steel construction with mesh clad shaft in black spray finish.

Duty Cycle

Based on 10 cycles per hour on a single shift basis.

MezzLight 250kg GoodsLift >

The MezzLight Mezzanine Lift is a simple, robust and versatile Mezzanine Floor GoodsLift for handling loads up to 250kg between floors in warehouses, factories, stores and workshops. Ideally suited for pallets or picking trolleys.

Features

- 250kg Maximum Working Load
- Floor mounted, no pit required (500mm long ramp provided)
- Self- supporting mesh-clad shaft
- Constant pressure control buttons at both levels
- Standard travel height up to 4m
- Standard usable platform size 1300mm x 1100mm, Will lift Euro & UK Pallets
- Same side or through car loading
- 2 stops (ground plus one level)
- 2m high double gates fitted with electrical & mechanical interlocks
- Emergency stop button
- Anti-slip platform surface
- BIM Content Available

CE marked and built-in conformance with:

- Machinery Directive 2006/42/EC
- Lifting Operations & Lifting Equipment Regulations
- The Provision & Use of Work Equipment Regulations

Options

- Bespoke platform sizes
- Increased travel height (up to 9m)
- Increased gate height (up to 2.5m)
- Up to 3 stops (ground plus two additional levels)
- Outside installation
- Choice of finish
- 90° loading or additional entrances
- Trolley stop barriers on platform
- Fully clad enclosure
- Level access onto lower level, if 50mm recess created by others



Technical Specifications – MezzLight 250kg GoodsLift

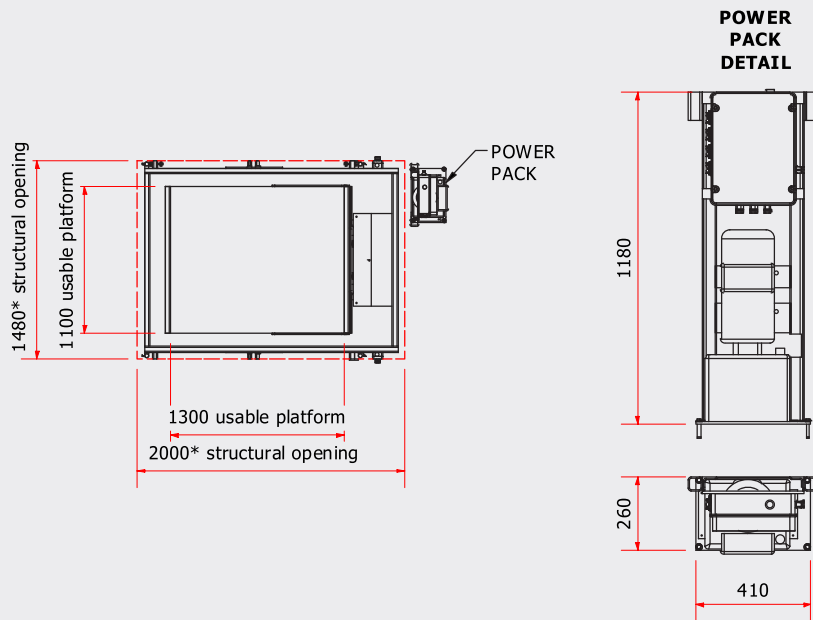
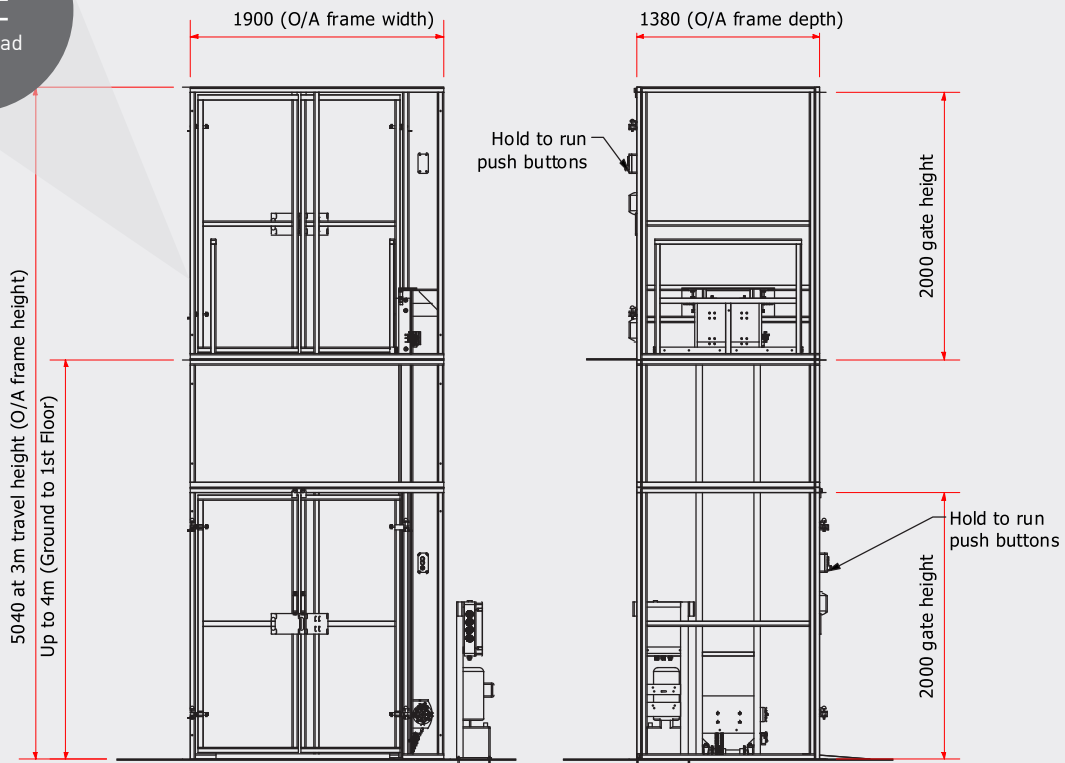

Power Supply

240 V, 20 A, 1ph terminated in a double pole isolator at lower level.

Construction

All steel construction with mesh clad shaft in black spray finish.

Duty Cycle

Based on 10 cycles per hour on a single shift basis.

MezzLight 3 Tier 250kg GoodsLift >

The MezzLight Mezzanine Lift is a simple, robust and versatile Mezzanine Floor GoodsLift for handling loads up to 250kg between three floors in warehouses, factories, stores and workshops.

Features

- 250kg Maximum Working Load
- Floor mounted, no pit required (500mm long ramp provided)
- Self-supporting mesh-clad shaft
- Constant pressure control buttons at all three levels
- Standard travel height up to 8m
- Standard usable platform size 1300mm x 1100mm, Will lift Euro & UK Pallets
- Same side or through car loading
- 3 stops (ground plus two levels)
- 2m high double gates fitted with electrical & mechanical interlocks
- Emergency stop button
- Anti-slip platform surface
- BIM Content Available

CE marked and built-in conformance with:

- Machinery Directive 2006/42/EC
- Lifting Operations & Lifting Equipment Regulations
- The Provision & Use of Work Equipment Regulations

Options

- Bespoke platform sizes
- Increased travel height
- Increased gate height (up to 2.5m)
- 2 stops (ground plus one additional level)
- Outside installation
- Choice of finish
- 90° loading or additional entrances
- Trolley stop barriers on platform
- Fully clad enclosure
- Level access onto lower level, if 50mm recess created by others

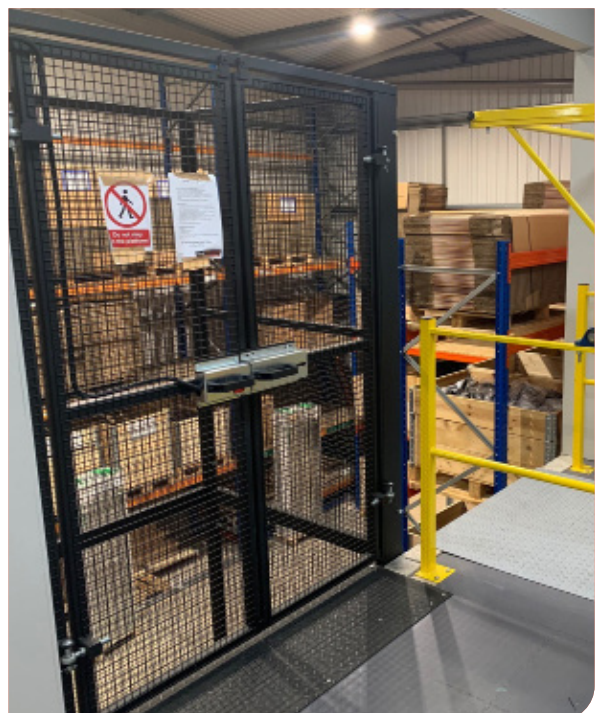

Technical Specifications – MezzLight 3 Tier 250kg GoodsLift

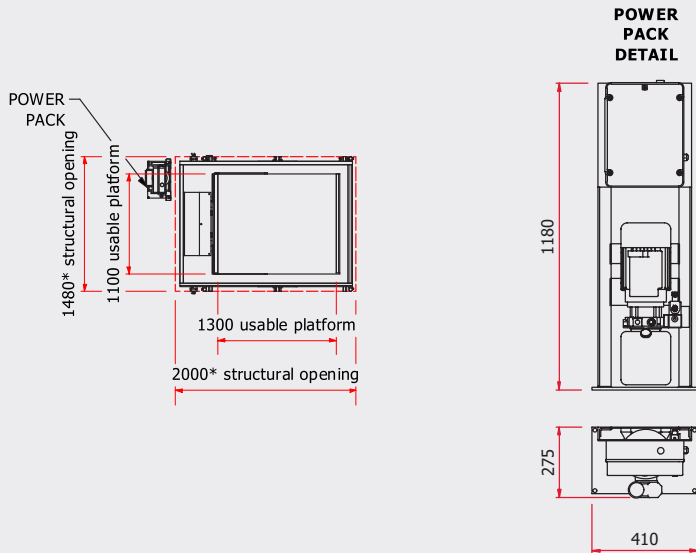
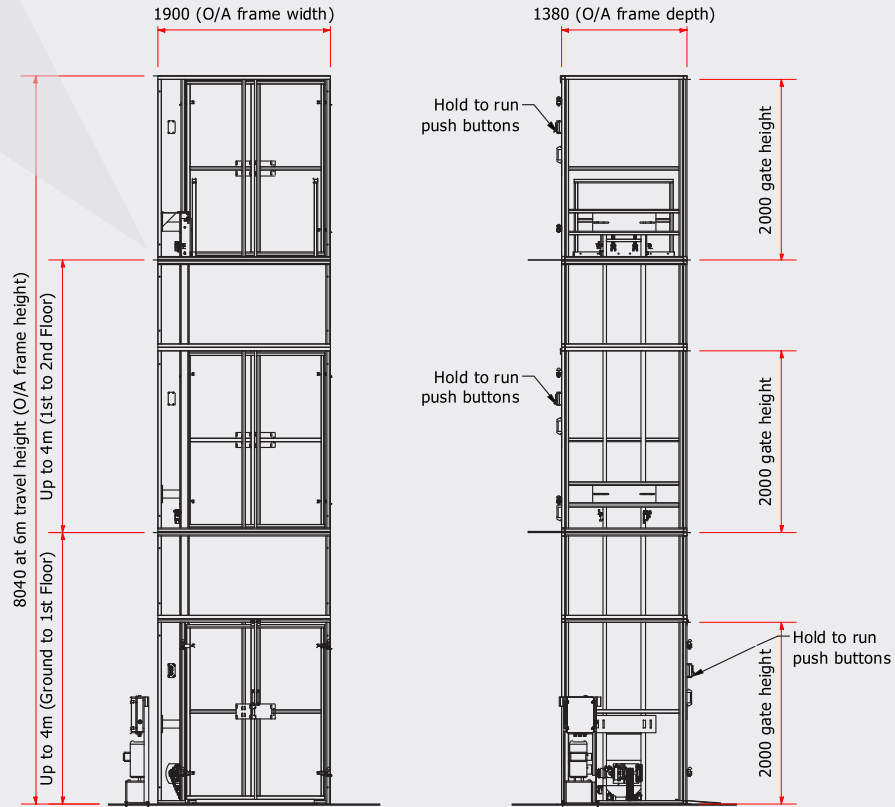

Power Supply

415 V, 20 A, 3ph and Neutral terminated in a triple pole isolator at lower level.

Construction

All steel construction with mesh clad shaft in black spray finish.

Duty Cycle

Based on 10 cycles per hour on a single shift basis.

MezzPro 500kg GoodsLift >

MezzPro Mezzanine Floor Lifts are an opposed mast mechanism which enables users to move goods such as pallets, trolleys or roll-cages on the standard platform size, safely and efficiently to secondary storage areas within buildings.

Bespoke larger platform sizes can be provided on this mechanism, commonly used for transporting bulky items such as car parts, sofas and picking trolleys.

Features

- 500kg Maximum Working Load
- Floor mounted, no pit required
- Self- supporting mesh-clad shaft
- Constant pressure control buttons at both levels
- Standard travel height up to 4m
- Standard usable platform size 1300mm x 1300mm
- Alternative large usable platform size 2000mm x 1000mm
- Same side or through car loading
- 2 stops (ground plus one level)
- 2m high double gates fitted with electrical & mechanical interlocks
- Emergency stop button
- Anti-slip platform surface
- BIM Content Available

CE marked and built-in conformance with:

- Machinery Directive 2006/42/EC
- Lifting Operations & Lifting Equipment Regulations
- The Provision & Use of Work Equipment Regulations

Options

- Bespoke platform sizes
- Increased travel height (up to 9m)
- Increased gate height (up to 2.5m)
- Up to 3 stops (ground plus two additional levels)
- Outside installation
- Choice of finish colour
- 90° loading or additional entrances
- Trolley stop barriers on platform
- Fully clad enclosure
- Level access onto lower level, if 50mm recess created by others



Technical Specifications – MezzPro 500kg GoodsLift

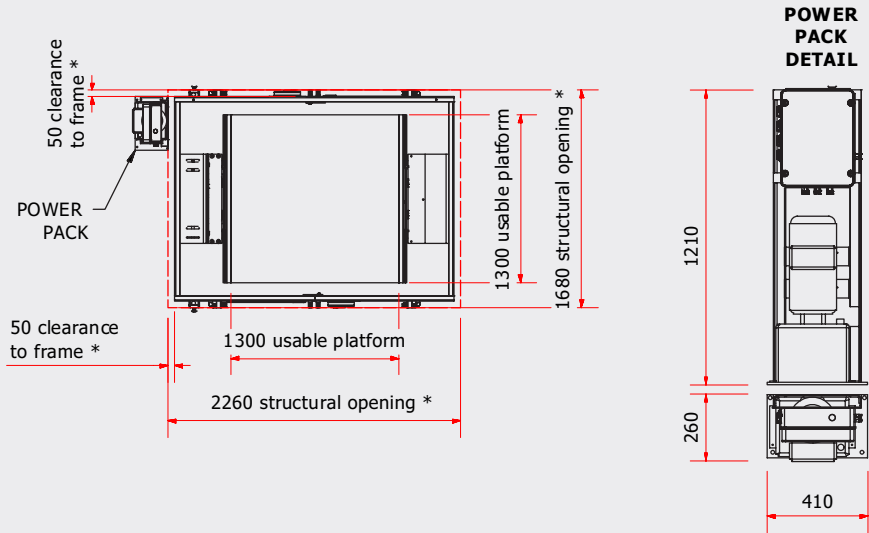
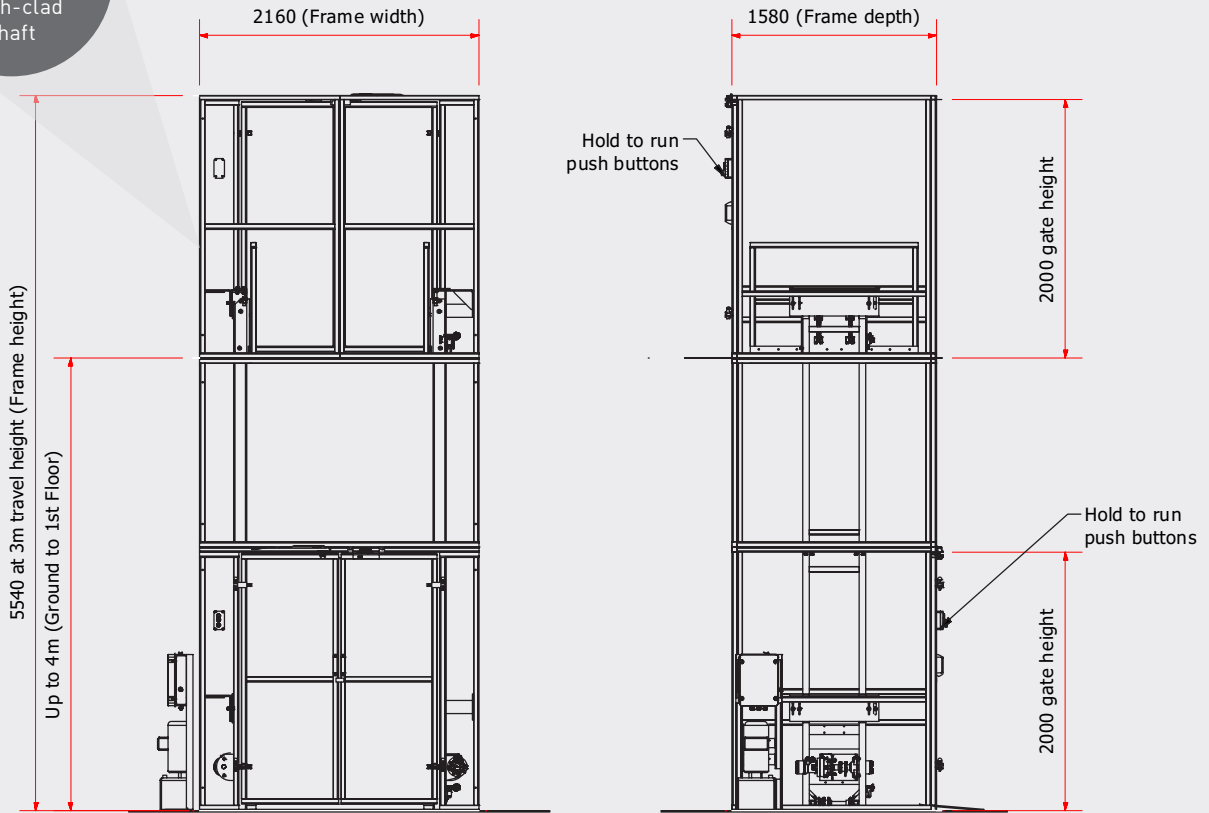

Power Supply

415 V, 2.2 kW, three phase and neutral supply terminated in a double pole isolator at lower level.

Construction

All steel construction with mesh clad shaft in black spray finish.

Duty Cycle

Based on 10 cycles per hour on a single shift basis.

MezzPro 3 Tier 500kg GoodsLift >

'Taking it to the next level'.

The 3 Tier MezzPro GoodsLift enables users to move goods such as trolleys or pallets safely and efficiently between floors.

Features

- Floor mounted, no pit required
- Self- supporting mesh-clad shaft
- Constant pressure control buttons at all three levels
- 500kg Maximum Working Load
- Standard travel height up to 8m
- Standard usable platform size 1300mm x 1300mm
- Same side or through car loading
- 3 stops (ground plus two levels)
- 2m high double gates fitted with electrical & mechanical interlocks
- Emergency stop button
- Anti-slip platform surface
- BIM Content Available

CE marked and built-in conformance with:

- Machinery Directive 2006/42/EC
- Lifting Operations & Lifting Equipment Regulations
- The Provision & Use of Work Equipment Regulations

Options

- Bespoke platform sizes
- Increased travel height
- Increased gate height (up to 2.5m)
- 2 stops (ground plus one additional level)
- Outside installation
- Choice of finish colour
- 90° loading or additional entrances
- Trolley stop barriers on platform
- Fully clad enclosure
- Level access onto lower level, if 50mm recess created by others



Technical Specifications – MezzPro 3 Tier 500kg GoodsLift

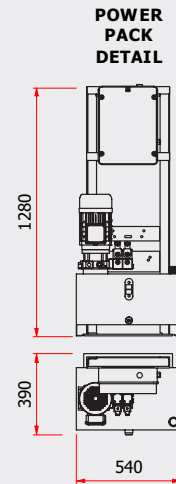
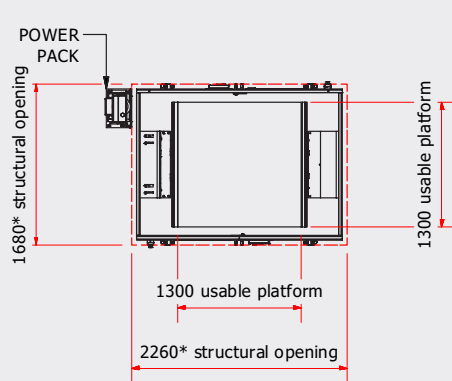
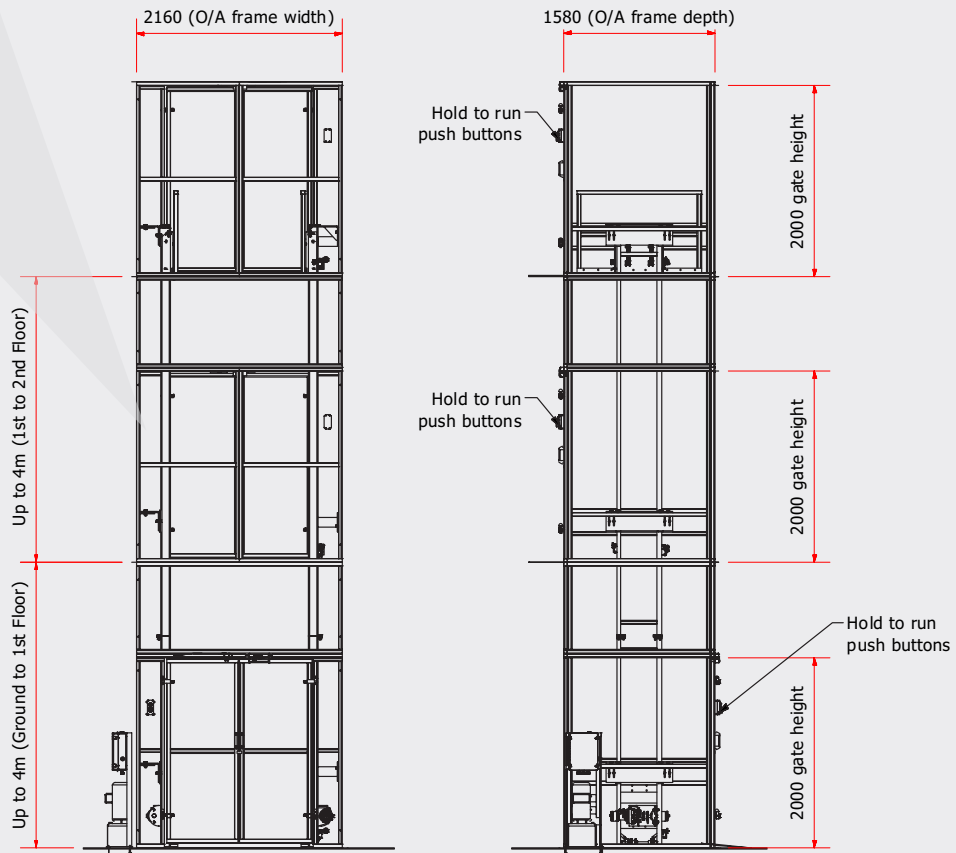

Power Supply

415 V, 2.2 kW, three phase and neutral supply terminated in a double pole isolator at lower level.

Construction

All steel construction with mesh clad shaft in black spray finish.

Duty Cycle

Based on 10 cycles per hour on a single shift basis.

MezzHD 1000kg GoodsLift >

The MezzHD is a simple, robust and versatile Mezzanine Floor Lift for handling loads up to 1000kg between two or three floors in warehouses, factories, stores and workshops.

Features

- 1000kg Maximum Working Load
- Floor mounted, no pit required (1000mm long ramp provided)
- Self- supporting mesh-clad shaft
- Constant pressure control buttons at both levels
- Standard travel height up to 4m
- Standard usable platform size 1500mm x 1500mm
- Same side or through car loading
- 2 stops (ground plus one level)
- Both level gates fitted with electrical & mechanical interlocks
- Emergency stop button
- Anti-slip platform surface
- BIM Content Available

Options

- Bespoke platform sizes
- Increased travel height (up to 9

m)

- Up to 3 stops (ground plus two additional levels)
- Choice of finish colour
- Additional entrances
- Trolley stop barriers on platform
- Fully clad enclosure



Technical Specifications – MezzHD 1000kg GoodsLift

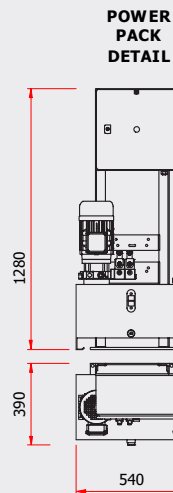
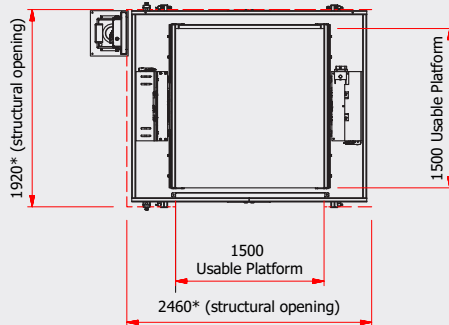
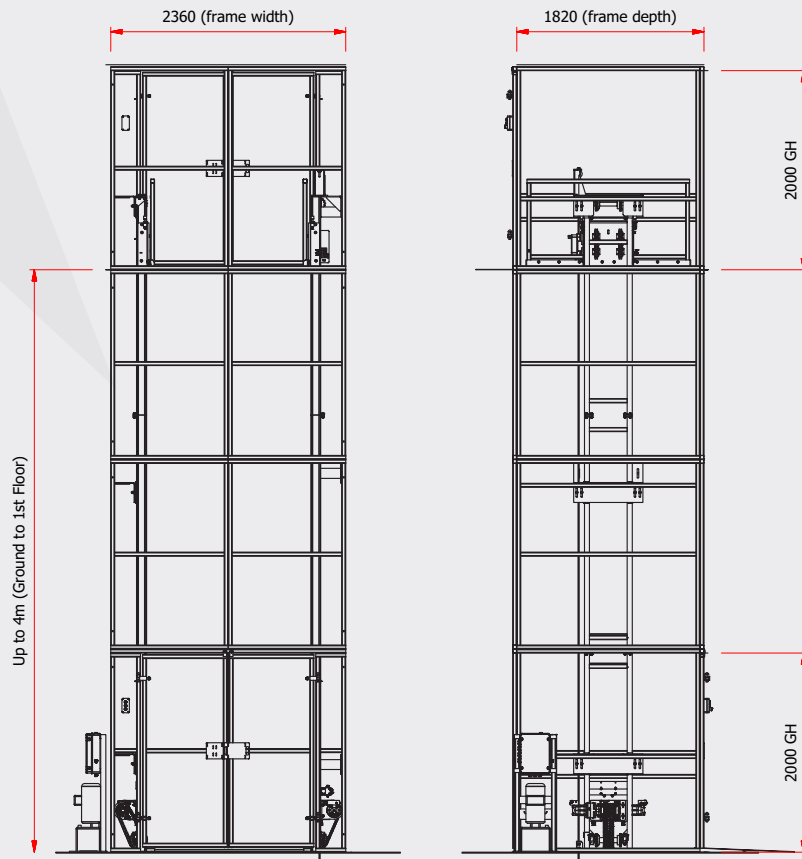

Power Supply

415 V, 2.2 kW, three phase and neutral supply terminated in a double pole isolator at lower level.

Construction

All steel construction with mesh clad shaft in black spray finish.

Duty Cycle

Based on 10 cycles per hour on a single shift basis.

MezzHD 3 Tier 1000kg GoodsLift >

'Taking it to the next level'

The 3 Tier Heavy Duty MezzLift enables users to move goods such as trolleys or pallets safely and efficiently between floors.

Features

- Floor mounted, no pit required (1000mm long ramp provided)
- Self- supporting mesh-clad shaft
- Constant pressure control buttons at all three levels
- 500kg Maximum Working Load
- Standard travel height up to 8m
- Standard usable platform size 1300mm x 1300mm
- Same side or through car loading
- 3 stops (ground plus two levels)
- 2m high double gates fitted with electrical & mechanical interlocks
- Emergency stop button
- Anti-slip platform surface
- BIM Content Available

CE marked and built-in conformance with:

- Machinery Directive 2006/42/EC
- Lifting Operations & Lifting Equipment Regulations
- The Provision & Use of Work Equipment Regulations

Options

- Bespoke platform sizes
- Increased travel height
- Increased gate height (up to 2.5m)
- 2 stops (ground plus one additional level)
- Outside installation
- Choice of finish colour
- Trolley stop barriers on platform
- Fully clad enclosure
- Level access onto lower level, if 50mm recess created by others

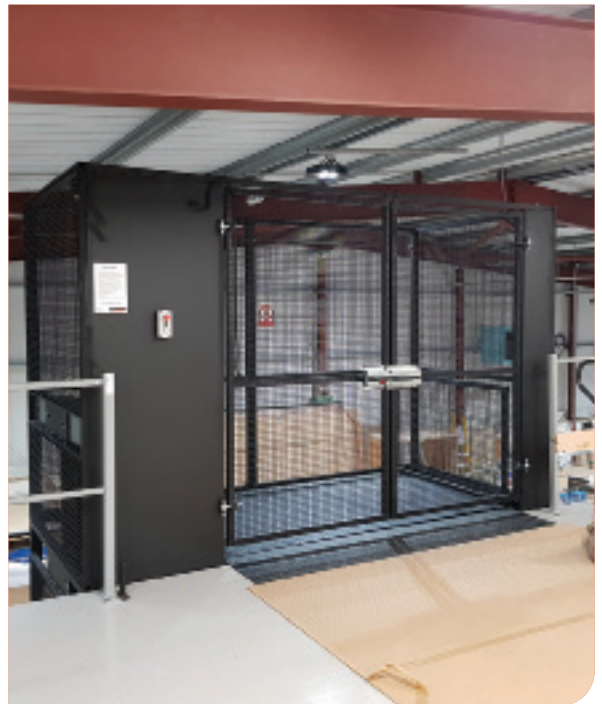

Technical Specifications – MezzHD 3 Tier 1000kg GoodsLift

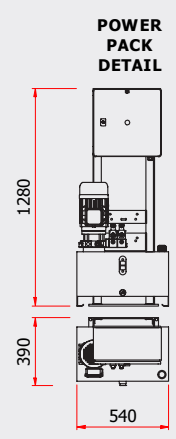
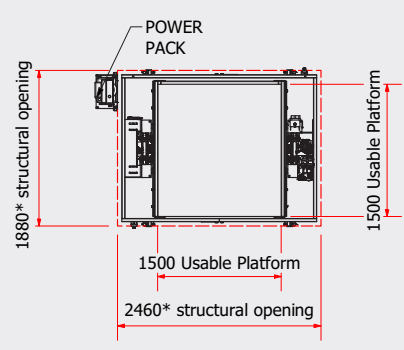
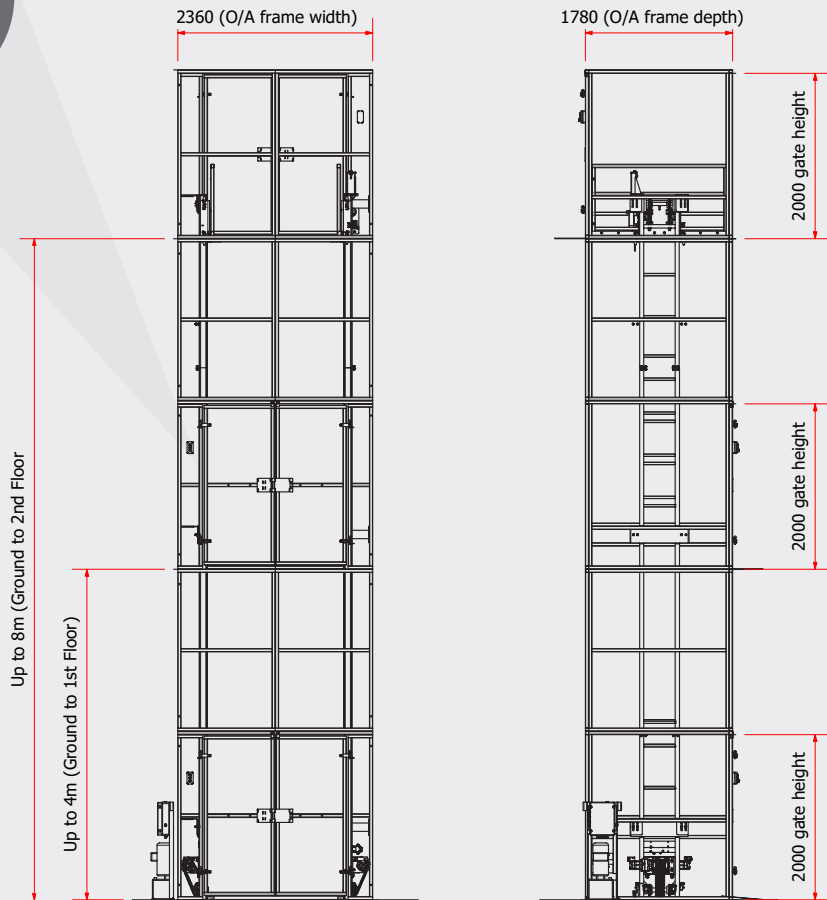

Power Supply

415 V, 20 A, 3ph and neutral terminated in a triple pole isolator at lower level.

Construction

All steel construction with mesh clad shaft in black spray finish.

Duty Cycle

Based on 10 cycles per hour on a single shift basis.

LightwellLifts >

The Penny Hydraulics range of LightwellLifts have been designed to make moving goods from the pavement down to basement level simple and safe.

Lightwells are increasingly being used as an access point to deliver bins / goods directly to basements; we designed the LightwellLift to allow for safe moving of goods between these levels.

Features

- Floor mounted, no pit required
- Self-supporting mesh-clad shaft, or guarded as required
- Constant pressure control buttons
- Up to 1000kg Maximum Working Load
- Bespoke platform sizes to suit available opening
- Bespoke guarding and loading arrangement to suit
- 2 or 3 stops (ground plus one or two levels)
- Suitable for external conditions
- BIM Content Available

CE marked and built-in conformance with:

- Machinery Directive 2006/42/EC
- Lifting Operations & Lifting Equipment Regulations
- The Provision & Use of Work Equipment Regulations

Options

- Bespoke platform sizes
- Increased travel height
- Increased gate height (up to 2.5m)
- 2 stops (ground plus one additional level)
- Outside installation
- Choice of finish colour
- 90° loading or additional entrances
- Trolley stop barriers on platform
- Fully clad enclosure



CellarLift

Clever designs for safe and efficient deliveries to pubs and restaurants.



The Problem

Traditional methods for deliveries to pub / restaurant cellars are back-breaking and hazardous. The safe systems of work are often disregarded in an effort to speed up the operation, this often results in damage to your premises, broken containers and even injury to staff.

The Answer

The CellarLift from Penny Hydraulics provides a robust, reliable and cost-effective mechanical handling solution to the problems associated with deliveries into cellars. Over 30 years of experience has gone into the CellarLift design which is in use with every major pub and restaurant owner in the UK.

Made in Britain, Built to Last

A CellarLift is a key part of your operation. Penny Hydraulics design, manufacture, install and offer ongoing service and maintenance packages to ensure performance throughout your ownership. Many of our CellarLifts have operated over 15+ years in the field.

Vertical CellarLift >

The Vertical CellarLift is the market leader – delivering outstanding performance time after time.

The Vertical CellarLift handles barrels and kegs up to 54 gallons, a double stack of crates or boxed goods whilst occupying the minimum of cellar space. It is widely used throughout the retail and licensed trade and is adaptable to suit most situations. Fully galvanised, it is designed to operate in the most arduous conditions, inside or out.

CellarLifts will carry cases and gas bottles as well as kegs – with a maximum capacity of 8 cases.

Features

- Suitable for all barrel sizes
- Carries a double stack of cases (max 8)
- Hold-to-run control
- No pit required
- Can operate outside
- CE marked
- Proven design
- BIM Content Available

Options

- Upgrade to carry wheelie bins
- Bespoke platform sizes
- Load through 90°
- Ongoing planned maintenance contract
- Many variants to cover most site situations



Technical Specifications – Vertical CellarLift

This is an example of a standard layout, however all lifts are designed and manufactured to your specific site requirements.

Side View

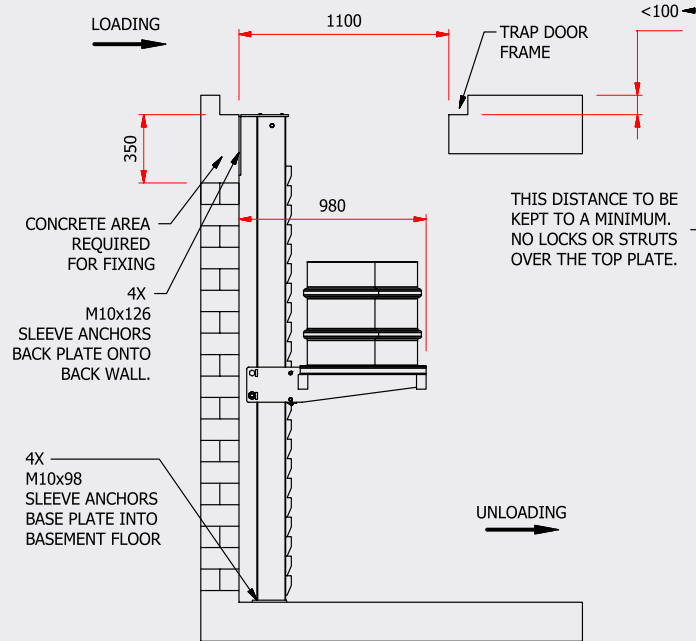

Front View

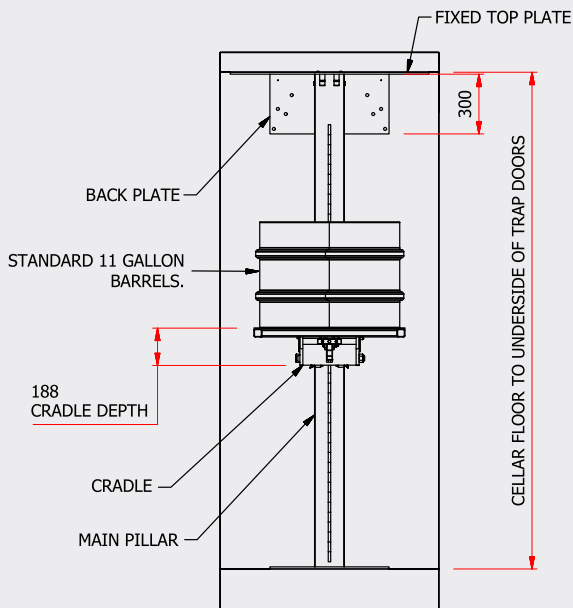

Plan View

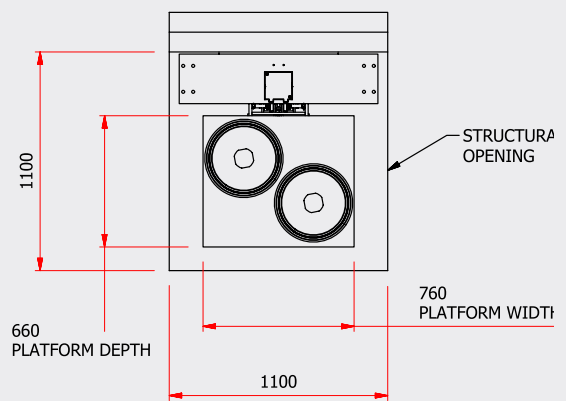

Power Supply

A 240 V, 20 A, 1ph terminated in a double pole isolator at lower level

Sloping CellarLift >

The Penny Hydraulics Sloping CellarLift is a unique device for handling barrels, crates and other food and drink related items between two floors in pubs, bars, hotels and restaurants which have an existing ramp or skid in place.

Following a site survey, each Sloping CellarLift is built to suit the angle of the ramp in the building and to minimise building works for the customer.

CellarLifts are widely used throughout the licensed trade to help operators reduce and eliminate manual handling and comply with health and safety regulations. It can be fitted with a cradle to handle a full 54-gallon barrel or small platform for general items weighing up to 210kg.

Features

- Suitable for all barrel sizes
- Can operate at any angle
- Carries a double stack of cases (max 8)
- Hold-to-run control
- No pit required
- CE marked
- Proven design
- BIM Content Available

Options

- Upgrade to carry wheelie bins
- Bespoke platform sizes
- Extended height to 8000mm
- Ongoing planned maintenance contract
- Many variants to cover most site situations
- Upgrade for outside use



Technical Specifications – Sloping CellarLift

This is an example of a standard layout, however all lifts are designed and manufactured to your specific site requirements.

Side View

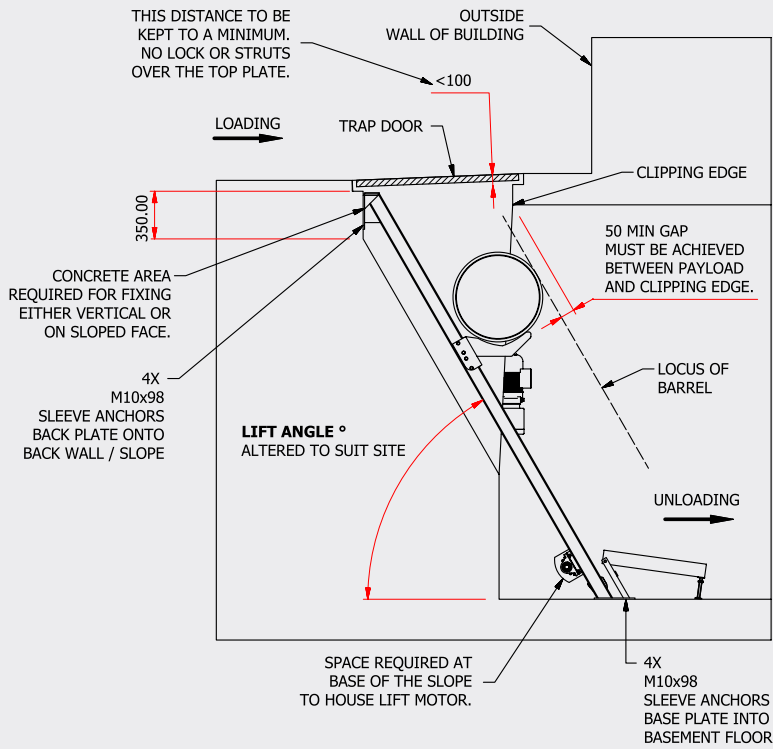

Front View

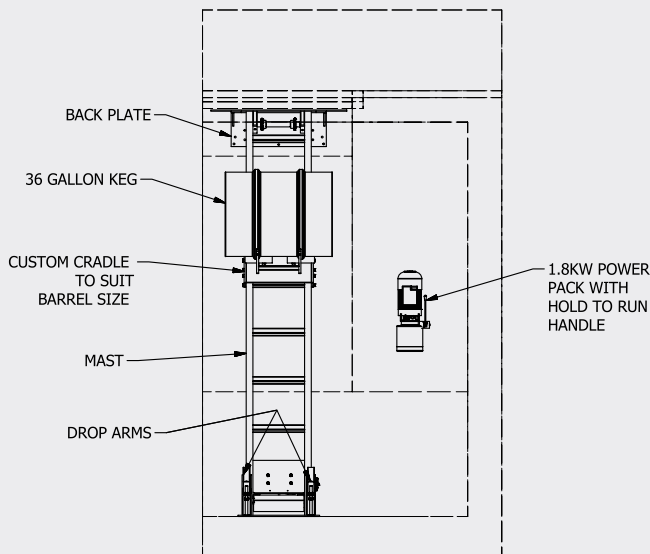

Plan View

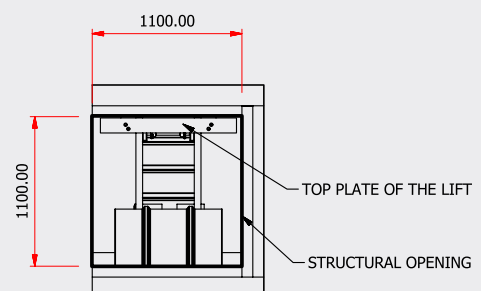

Power Supply

A 240 V, 20 A, 1ph terminated in a double pole isolator at lower level

CaseHoists >

Our range of CaseHoists have many uses, from pavement deliveries for retail outlets, to re-stocking the bar from a basement store.

For those who need to lift a larger volume of goods between floors the Double Stack CaseHoist can move up to 8 cases at a time with a maximum working load of 210kg.

Features

- Standard range from 80kg to 250kg maximum working loads
- Hold-to-run control
- No pit required
- CE marked
- Proven design
- BIM Content Available

Options

- Upgrade to carry wheelie bins
- Bespoke platform sizes
- Extended height to 8000mm
- Ongoing planned maintenance contract
- Many variants to cover most site situations
- Upgrade for outside use



BayLift >

The Penny Hydraulics BayLift is ideal for lifting and handling loads between levels with just a small change in height, such as loading bays and docks.

The low lifting height and no need for a lift pit means the BayLift can offer a practical load handling solution compared to alternatives such as conventional scissor or platform lifts.

A range of BayLifts are available with capacities up to 1000kg and with a variety of platform sizes to ensure the BayLift can safely handle crates, pallets, roll cages, sack barrows and many other loads. A range of guarding arrangements are available, depending on the specific requirements of the site.

Features

- 500kg or 1000kg maximum working load
- Platform size up to 2400mm x 1500mm
- Folding barrier on platform
- 2 stop lift, up to 1500mm travel height
- Constant pressure control
- Floor mounted, no pit required
- Folds away after use
- BIM Content Available

Options

- Bespoke platform sizes
- Trolley stop or anti-roll-off toe on platform
- Outside installation
- Free standing mounting bracket
- Full mesh clad enclosure
- Interlocked gates
- Additional travel height up to 2m



We've Got You Covered

We offer nationwide service and maintenance programmes for Penny Hydraulics equipment. So, you can keep your business moving and stay on the right side of the law.

Whether you have a fault or are due your annual service, Penny Hydraulics is on hand. We offer two planned maintenance programmes, Standard and Fully Comprehensive.

All our service agreements cover a minimum of one year's servicing to ensure you meet regulations with annual checks. We also provide 'thorough examinations' – a statutory requirement that needs to be carried out every six or twelve months.

Expertise you can trust

Our office-based service team are constantly in touch with our field engineers meaning your service calls will be dealt with quickly, minimising downtime, increasing efficiency and ensuring the safety of your workforce.

With over 40 years' experience in service and maintenance, we have many special-order national service programmes in place covering multiple sites across the UK, each with an impressive first-time fix rate. We also boast over one hundred 10/10 NPS feedback scores. So, you can rest assured that you and your equipment is in the safest hands possible.

Ready to learn more about our service packages – www.pennyhydraulics.com/services >

Case Study

Regather Install a MezzLift to Aid Growth Throughout Pandemic



The Brief

As demand for the fruit and veg boxes grew – space became a premium. Initially, a marquee was put up to extend space outside the building, but this was not a suitable long term solution.

‘It came to a point where we either needed to move premises or look for other solutions to reconfigure the building’ says Gareth Roberts founder of Regather. ‘Due to the pandemic moving the business was not a viable option. After much consideration, we decided to repurpose the event space upstairs into another working area. The problem then was getting the 600 – 700kg of produce safely between floors’.

Read more at – www.pennyhydraulics.com/case-studies/regather-goods-lift-case-study/ >

To find out what’s new at Penny Hydraulic’s, visit our “Latest News” page on our website:

<https://www.pennyhydraulics.com/news/>

Customer Feedback

“

Excellent company to work with. Product was delivered on time and the site team was very professional.

”

ADAM TOMLINSON, SHAWPAK

“

Great service and very friendly staff. The procedure has been done in a minimal time, working area left tidy and in full working conditions.

”

VADIM ANHIMOV, CLASSIC FOOTBALL CO LTD

“

Great team to work with from point of quotation, to order to installation. They work with you and always try to make it fit around you, we had a few hick-ups along the way but it was never an issue, as long as you communicate with them.

”

ADNAAN MARBAN, PC SPECIALIST LTD

“

Technical support for product selection and detail design was responsive and competent. Installation went according to plan. The product works as intended and is reliable. Service tech is helpful & pleasant and the price was reasonable.

”

EURING SIMON DOBSON CENG MIMECHE, BUCKLEYS UVRAL LTD

Key



Penny Hydraulics HQ



Your Local Engineer

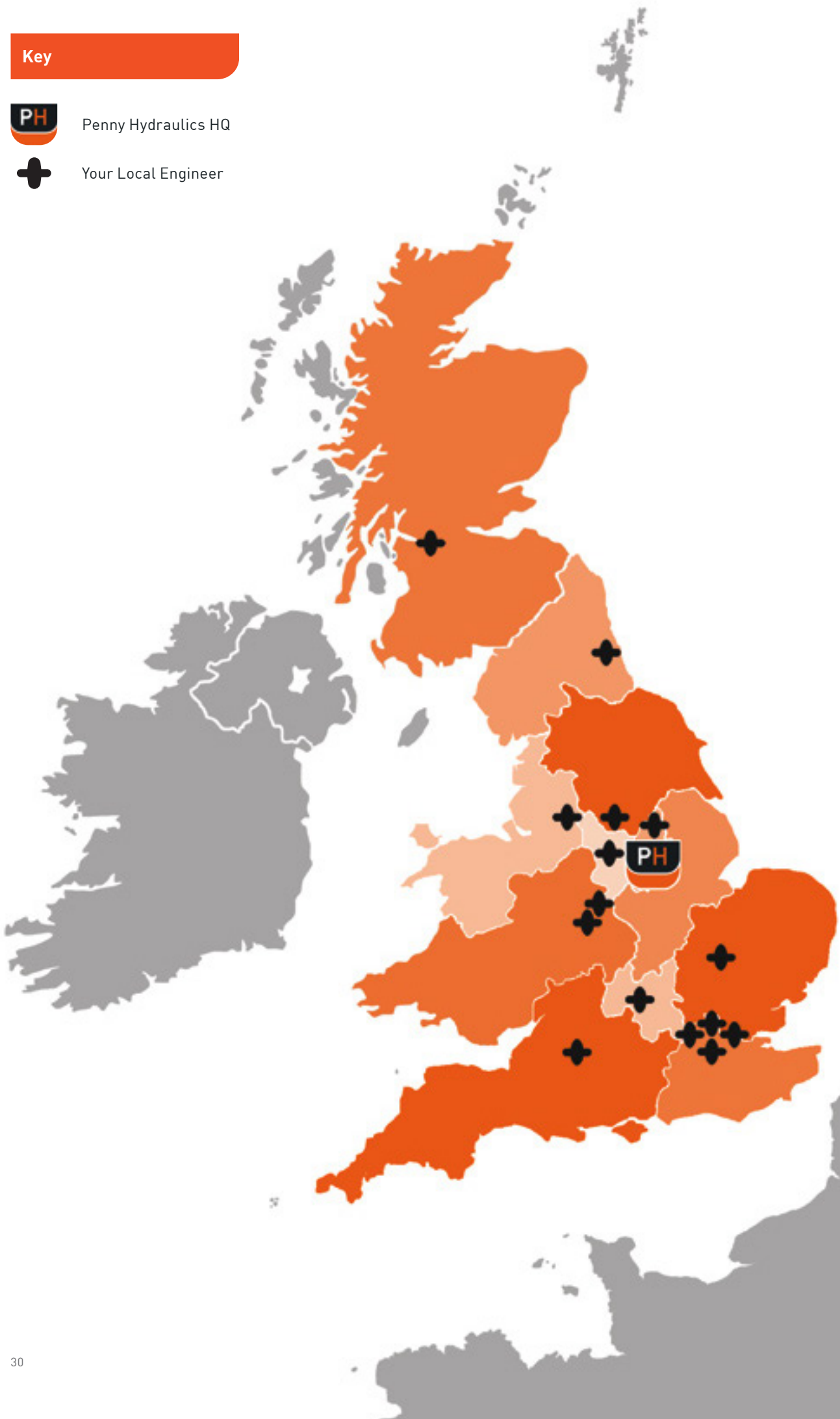

Need further help?

Please don't hesitate to get in touch.

+44 (0) 1246 811475

sales@pennyhydraulics.com

Penny Hydraulics Ltd, Station Road
Clowne, Chesterfield, Derbyshire
S43 4AB, United Kingdom

www.pennyhydraulics.com

Click on the links to follow us on
social media!

[Facebook](#)

[Twitter](#)

[Linkedin](#)

Contact Us

